



TYPICAL

GC20606 / GC20606-1

**SINGLE NEEDLE/DOUBLE NEEDLE MEDIUM AND HEAVY
DUTY COMPOUND FEED LOCKSTITCH SEWING MACHINE**

OPERATION INSTRUCTION / PARTS MANUAL

CONTENTS

Operation instruction

1. Brief introduction	1
2. Main specifications	1
3. Installation and preparation	1
3.1 Installation	1
3.1.1 Location of the machine	1
3.1.2 Installing oil reservoir.....	1
3.1.3 Mounting machine head.....	1
3.1.4 Mounting kneelifter.....	2
3.1.5 Installing the motor	2
3.1.6 Connecting the clutch lever to the pedal	3
3.1.7 Installing the thread winder	3
3.1.8 Installing the thread spool stand	3
3.2 Preparation	3
3.2.1 Cleaning the machine.....	3
3.2.2 Examination.....	4
3.2.3 Precaution before start.....	4
4. Operation	5
4.1 Coordination between needle thread and sewing material	5
4.2 Installing the needle	5
4.3 Winding the bobbin thread	5
4.3.1 Winding method	5
4.3.2 Winding adjustment	6
4.3.3 Threading.....	6
4.3.4 Stich length and reverse sewing control	6
4.3.5 Setting the bobbin	7
4.3.6 Drawing thread from the bobbin.....	7
5. Machine adjustment	7
5.1 Thread tension adjustment	7
5.2 Adjusting the pressure of presser foot	8
5.3 Use and adjustment of the safety clutch device	8
5.3.1 The function of the safety clutch device.....	8
5.3.2 Resetting the safety clutch device.....	8
5.3.3 Regulating the strength on the safety clutch device	9
5.4 Upper feed adjustment.....	9
5.5 Presser foot lift volume adjustment	10
5.6 Hook oil amount adjustment	10

Parts manual

1. GC20606 Arm parts	11	14
2. GC20606-1 Arm parts	15	18
3. Upper shaft and presser foot parts	19	22
4. GC20606 Needle bar motion and Lower feed parts	23	26
5. GC20606-1 Needle bar motion and Lower feed parts	27	30
6. GC20606 Rock shaft and thread looping parts	31	34
7. GC20606-1 Rock shaft and thread looping parts	35	38
8. Stitch length adjusting parts	39	40
9. Knee lifter parts	41	44
10.GC20606 Lubrication parts	45	48
11.GC20606-1 Lubrication parts	49	52
12.Accessories	53	54

1. Brief introduction

Both the models adopt straight twin-needle and two horizontal hooks with auto lubrication for thread looping, sliding lever for thread take up to form two lines of lockstitch seam. The upper shaft and lower shaft is connected by ball bearing and driven by teeth-type synchronic belt; plunge oil pump lubrication system. They adopt the compound feed mechanics of feed dog, needle bar and presser foot, even if for long stitch length and long material, They can deal with them freely.

They are widely used in factories of suitcase, tent, cushion, leather goods, apparel, mat, etc..

The difference between the two models:

SS20606 adopts twin-needle, two large horizontal hooks with auto lubrication. With the parts it can form ten different needle gauges.

SS20606-1 adopts single needle and form single line double lockstitch form.

2. Main Technical Specification

1 Application:	medium and heavy duty materials
2 Max. sewing speed:	2000 spm
3 Max. Stitch length :	9 mm
4 Needle bar stroke:	36 mm
5 Presser foot lift height:	8mm(by hand); 16mm(by knee)
6 Hook:	large horizontal hook with auto lubrication
7 Needle:	DP 17 Nm125~180
8 Lubrication:	pump auto lubrication (partial of manually oiling)
9 Needle gauge: (Twin-needle)	6.4, 3.2, 4, 4.8, 8, 9.5, 12.7, 16, 19, 25.4
10 Motor power:	0.37 kw (clutch motor)

3. Installation and preparation

3.1 Installation

3.1.1 Location of the machine

To ensure a smooth running, the machine should be located on rigid and flat floor. The insert of rubber mat between machine stand and floor is recommended for further reducing the running noise and vibration.

3.1.2 Oil Reservoir Installation(Fig.1)

Put the oil reservoir into the table cutout, and place the four cushions on the four corners of the cutout, and place oil felt into the oil reservoir.

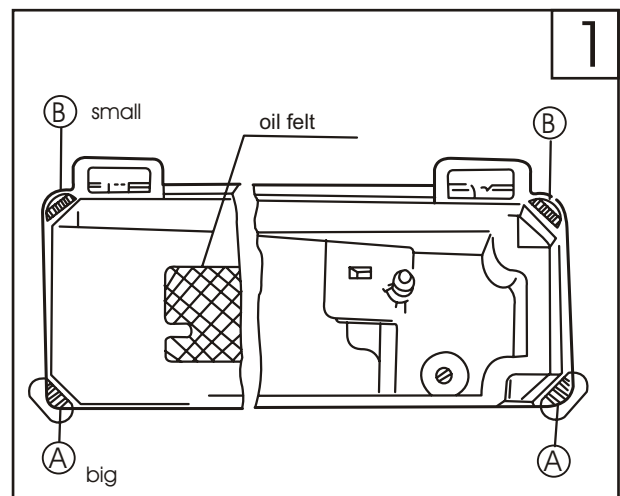

3.1.3 Mounting machine head(Fig.2)

Make the hinge (A) of machine head engaged with hinge socket (B) on the table, then turn the machine head freely till it is seated on the frame of table cutout.

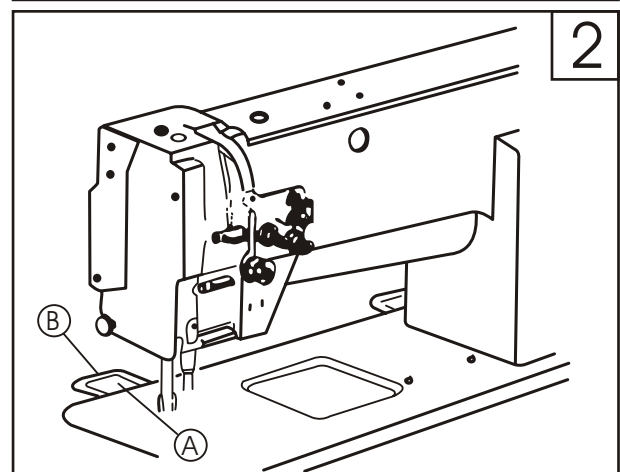

3.1.4 Knee control presser foot lifter installation(Fig.3)

a. Installing

Install Connector (A) , Bell Crank (B) , Bell (C) in the order shown in Fig.3.

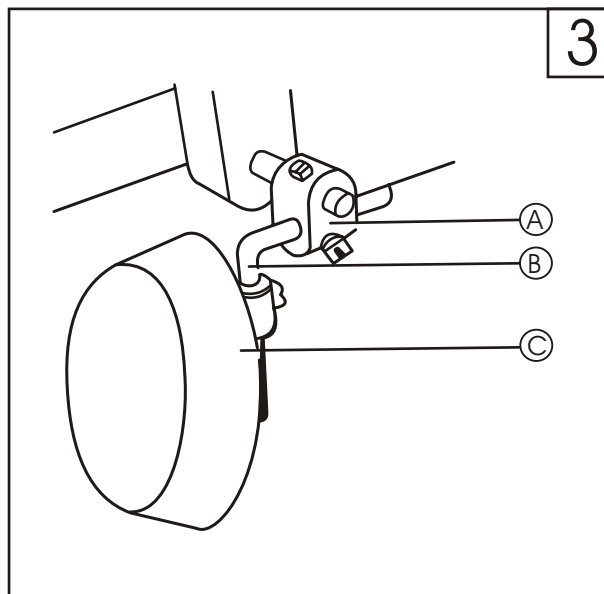

b. Adjustment (Fig.4)

In the order of the following:

1. When the presser foot is at its lowest position, keep the crank in the position shown by b in the figure, turn Knee Control Stop Adjusting Screw (C) to touch with the oil reservoir, and tighten the nut of Screw (C) .

2. When operate by knee, the presser foot lift volume is controlled by Screw (B) . Turn the presser foot lever down, make the bell in the position shown by a in the figure, lift the presser foot to 13 mm, adjust Screw (B) to touch the oil reservoir. Then tighten the nut of Screw (B) .

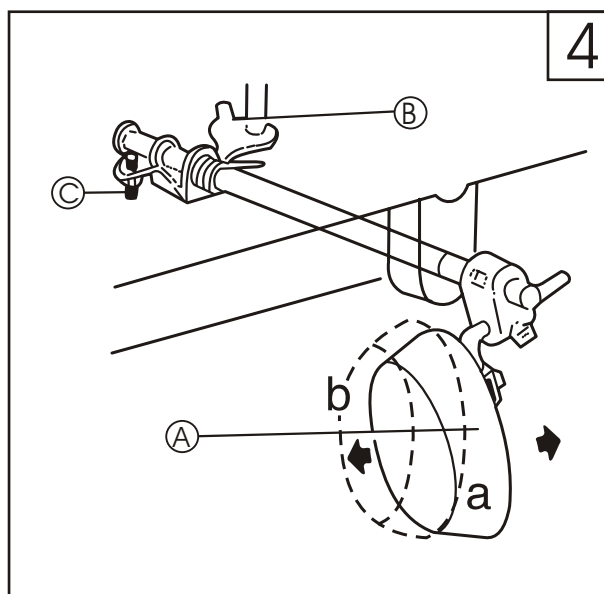

3.1.5 Installing the motor (Fig.5)

Align machine balance wheel belt groove (A) with motor pulley belt groove (B) by moving the motor (C) leftward or rightward. Be sure the belt is not touch with table.

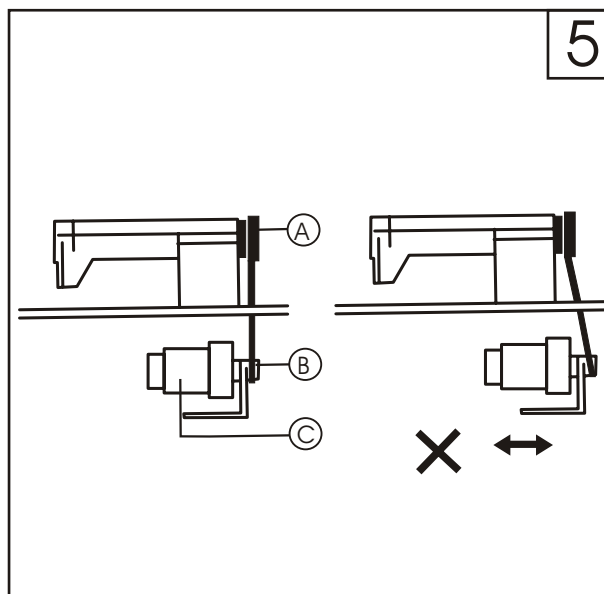

3.1.6 Connecting the clutch lever to the pedal (Fig.6)

1)The optimum tilt angle of pedal (A) with floor is approx.30 degree.

2)Adjust the clutch of the motor so that clutch lever (C) and draw bar (B) run in line.

3)The machine balance wheel should rotate counterclockwise for normal sewing when view from opposite side of balance wheel (G). The motor is rotated in the same direction. The rotation can be reversed by reversing (turn over 180 deg.)the plug of motor.

4)Adjust the tension of V-belt (F) by moving the motor vertically. The proper tension of V-belt is a slack of 10-12mm when the belt is depressed at the belt span by finger.

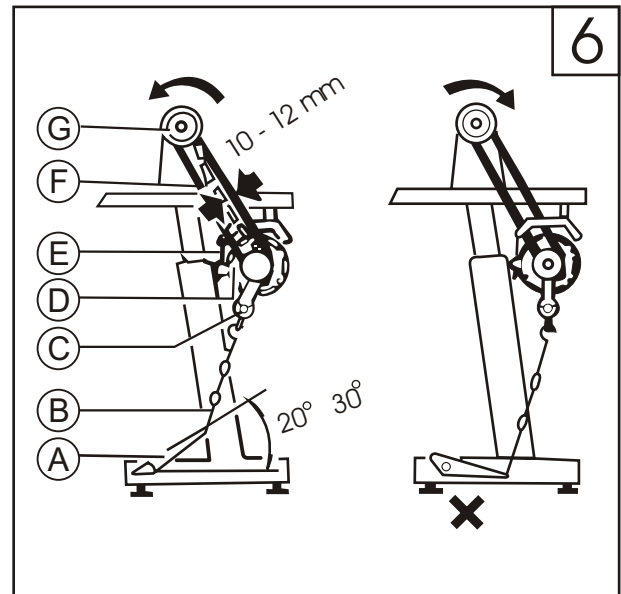

3.1.7 Installing the bobbin winder (Fig.7)

Align pulley (B) of bobbin winder with outside of belt (C) and should be kept a proper clearance between them, so that pulley B could be contacted with belt after the stop latch thumb lever (A) depressed, thereby belt drives the pulley B while machine running. After check bobbin winder is in parallel with belt slit E of table, fastened by two wood screws (D).

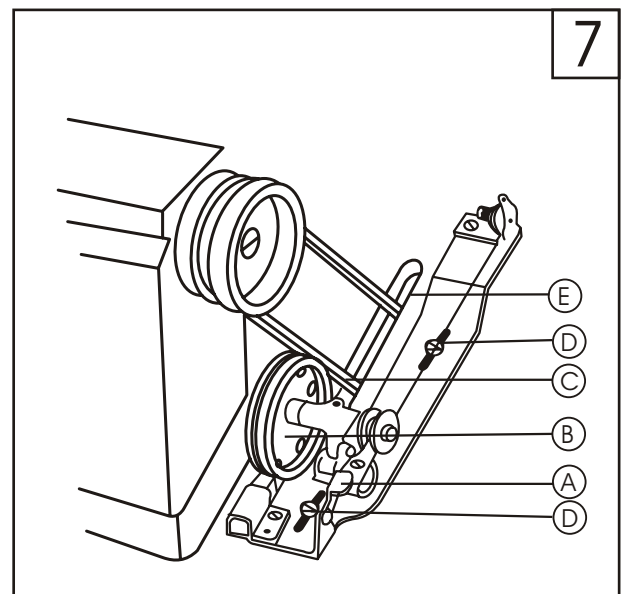

3.1.8 Installing the thread spool stand (Fig.8)

Locate thread spool stand at the right front of the table, note that spool rest may not obstruct when machine head is turned backward, then tighten wood screw.

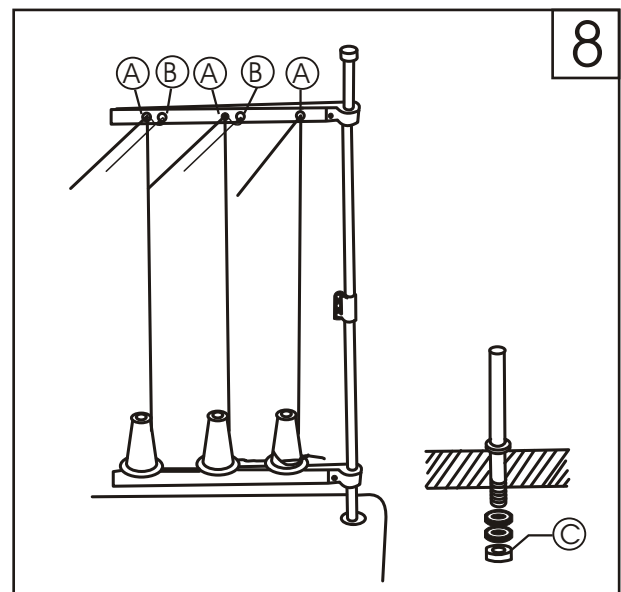

3.2 Preparation

3.2.1 Cleaning the machine

Before delivery, the machine parts are coated with rust preventive grease, which may be hardened and contaminated by dust during storage and shipment. The grease must be removed by clean cloth with gasoline.

3.2.2 Examination

Though every machine is confirmed by strict inspection and test before delivery, the machine parts may be loosed or deformed after long distance transportation with jolt. A thorough examination must be performed after cleaning the machine. Turn the balance wheel to see if there is running obstruction, parts collision, uneven resistance or abnormal noise. If these exist, adjustment must be made accordingly before run.

3.2.3 Precaution before Start

a. Oiling (Fig.9)

Oil amount should be filled according to the marks in the oil reservoir. Mark (H) refers to the highest of oil amount; (L) refers to the lowest, be careful that the oil amount should not be lower than Mark (L), otherwise the machine parts can not be fed with oil and cause overheat and collision.

Be sure to use machine oil HA-8 or HJ-7

b. When the machine starts for the initial time or reuse after a long period of time, the proper oil amount should be filled in sections of machine shown by arrows in Fig.10,11. When it is in operation, observe the oil sparking in oil screen to check the oil condition.

Note: when the machine needs drop oiling, do not start before drop oiling.

c. When a new machine starts running, for extending its life, please run at a medium and low speed (1000 spm) for about a month and then raise the speed gradually.

d. Please turn off the power when it is not in use or the operator leaves away from it.

e. Replace the oil every month. When replacing, fully drain off the old oil in the reservoir and add the new one.

f. The needle gauge options are: 6.4, 3.2, 4, 4.8, 8, 9.5, 12.7, 16, 19, 25.4 For getting it, the throat plate, presser foot or alternating foot, needle holder, feed dog, left and right sliding plates, thread guide should be changed. It is provided with 6.4mm when it leaves off the factory, For the other size, the relevant parts can be ordered from the factory.

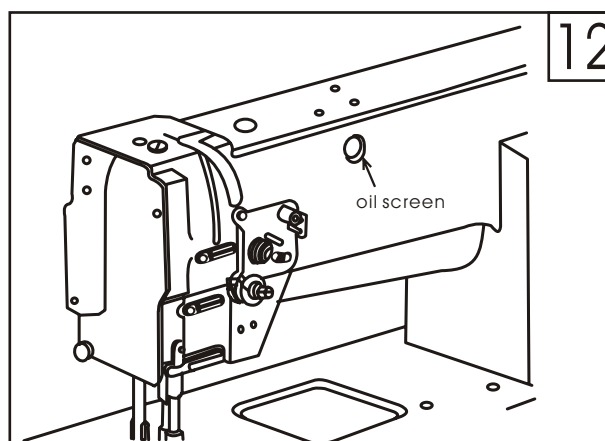
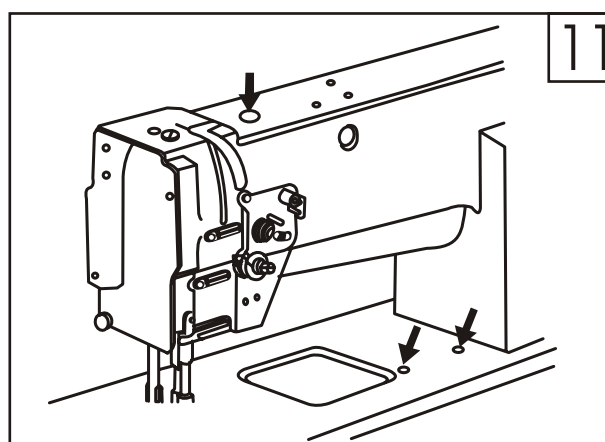
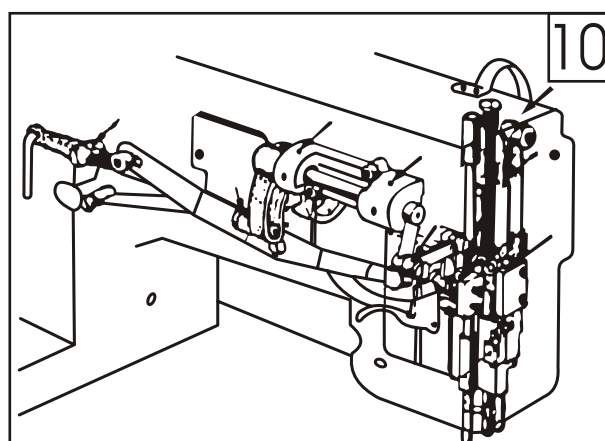
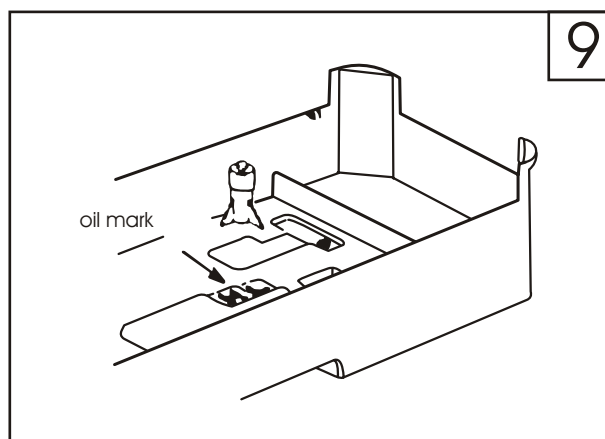

4. Operation

4.1 Coordination between needle, thread and sewing material

Please use needle DP 17,Nm125-180.The coarseness of needle should be in accordance with the nature of material. If stitch on heavy duty material with a slim needle, the needle will be easily bent, skip or thread breakage occurs, on the contrary, stitch on tightly woven material with a very coarse needle, the material will be destroyed with over-big needle. So the needle and thread should be properly selected.

4.2 Needle installation(Fig.13)

Turn the balance wheel to lift needle bar to the highest position, loosen Needle Set Screw **(A)** , fully insert the needle shank up to the bottom of needle socket, keeping the long grooves of the two needles opposite with each other, then tighten Screw **(A)** , For single needle, keep the long groove of needle facing the left of the operator. See Fig(b).

Note: Fig.(c): insufficient insertion.

Fig.(d) : wrong direction of needle long groove in insertion.

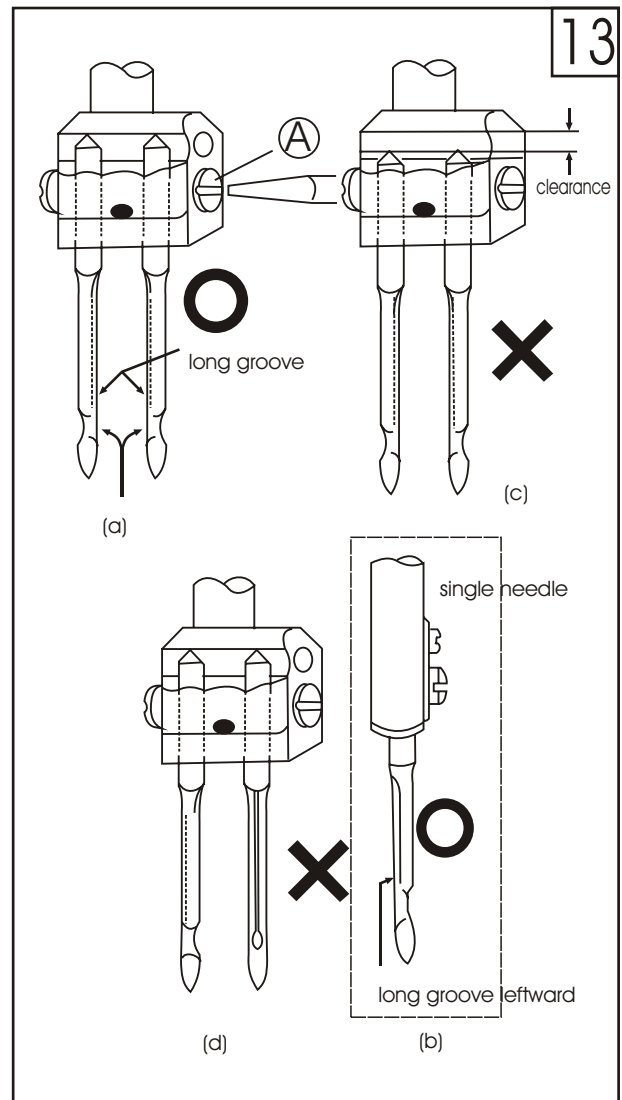

4.3 Winding the Bobbin thread

4.3.1 Winding method(Fig.14)

- 1) Install bobbin **(A)** to bobbin winder spindle **(B)** .
- 2) Pass thread **(C)** from spool through the eye 1 on tension bracket **(E)** . Pass it between tension discs 2 , and then wind the end of the thread a few turns on the bobbin.

3) Push stop latch thumb lever **(D)** down to lock the bobbin, the winder pulley **(F)** is thereby pressed on belt **(G)** .

- 4) Start the machine to wind thread.

Note when thread is wound without sewing operation, be sure to keep the presser foot lifted.

- 5) When the thread is fully wound, the bobbin winder stop latch automatically release the bobbin winder, thus stopping the winding motion.

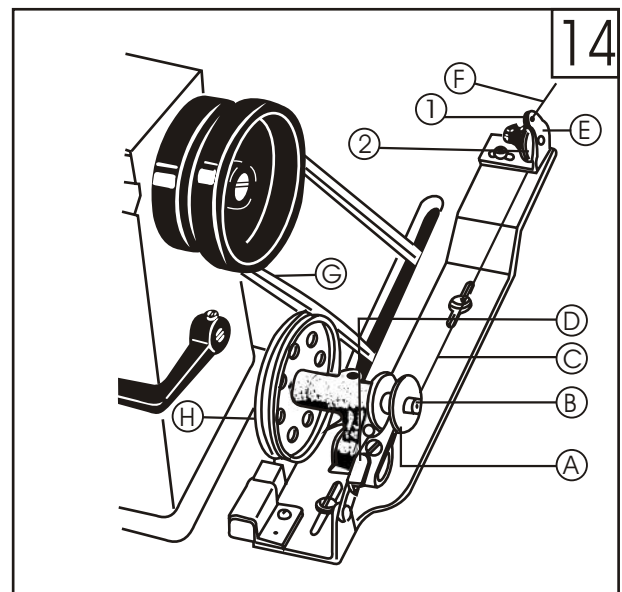

4.3.2 Winding adjustment (Fig.15)

1) Wound bobbin thread should be neat and tight, if not, adjust the thread tension by turning tension stud thumb nut (A) of bobbin winder tension bracket.

Note: nylon or polyester thread should be wound with light tension, otherwise bobbin (D) might be broken or deformed.

2) When the wound thread layer does not present a cylindrical shape as in Fig.15a, loosen tension bracket screw (B) and move tension bracket (C) leftward or rightward. If thread is wound as shown in Fig, 15b, move the tension bracket rightward, while if thread is wound as shown in Fig.15c,move the tension bracket leftward, After adequately positioning the tension bracket, tighten screw (B).

3) Do not over fill the bobbin, the optimum capacity of thread will fill about 80% of bobbin outside diameter, this can be adjusted by stop latch screw (E).

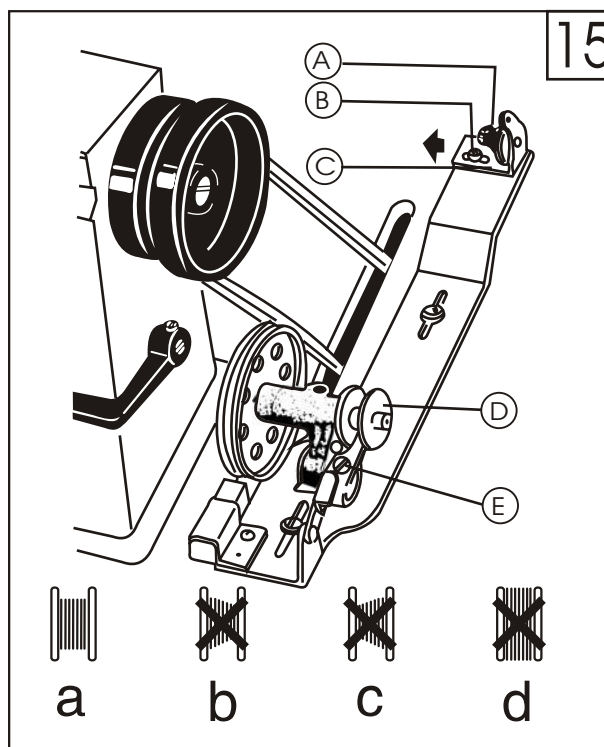

4.3.3 Threading (Fig.16)

Every thread should be drawn through Thread Hole (A), when use light and smooth thread (polyester or long silk thread), it should be drawn through Hole (B), Keep the thread take-up lever in its highest position, draw every thread in the following numerical order.

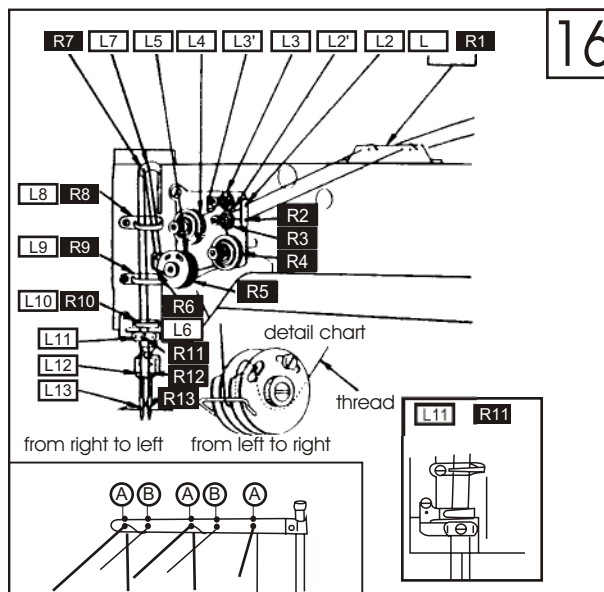

4.3.4 The stitch length and forward and reverse sewing control (Fig.17)

The stitch length can be regulated by Stitch Length Dial (A). Turn it counter-clockwise to expand its length and clockwise to shorten its length. The numbers on Dial (A) show the sizes of the stitch length in mm.

For reverse feed, press down Release Feed Lever (C) to perform reverse sewing, Release the lever, the reverse feed lever can reset automatically and the forward sewing is resumed.

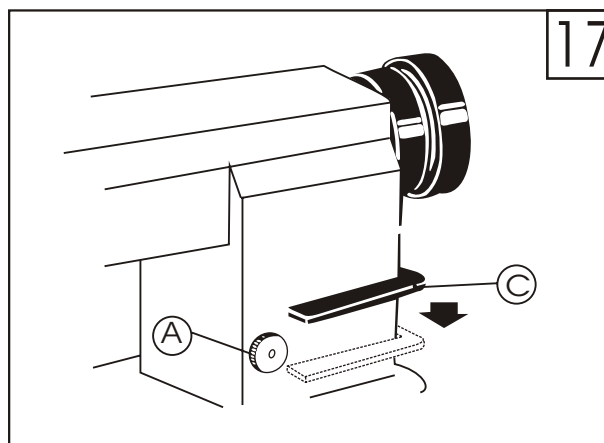

4.3.5 Placing bobbin (Fig.18)

Note: when bobbin is placed into the bobbin case, the thread should be wound properly in the correct direction shown in the figure.

4.3.6 Drawing thread from the bobbin (Fig.19)

- a. Draw the thread end to Bobbin Slot (1) shown in the figure, and pull it out down through the inner bobbin stop piece.
- b. Hold the thread with left hand, turn the balance wheel slowly and get the bobbin thread, then draw them a little apart from the presser foot.

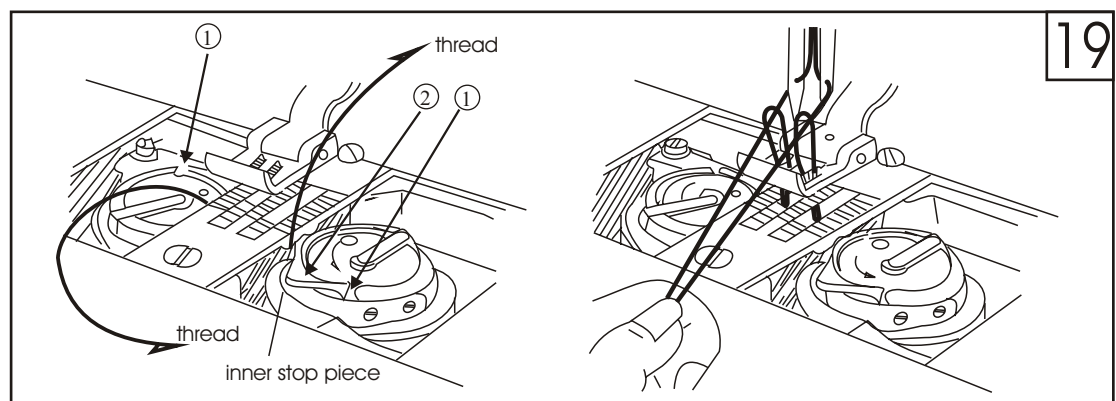
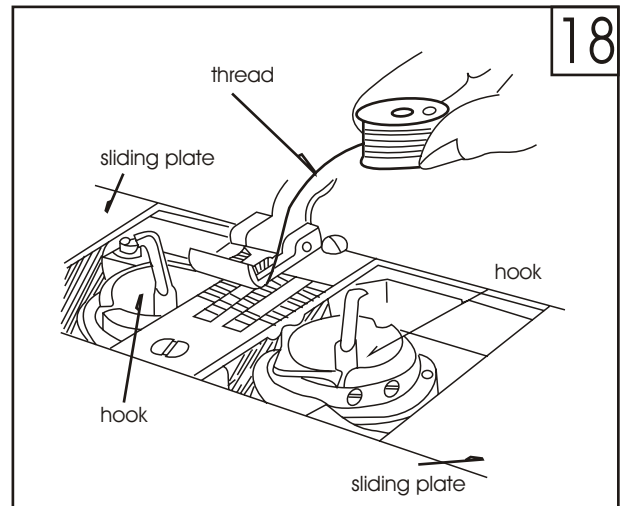

5. Machine Adjustment

5.1 Thread tension adjustment

All forms of stitches are shown in Fig.20.

The normal stitch of sewing machine is shown as Fig.(A) If stitch is abnormal, the puckering and thread breakage will occur, and the needle thread tension and bobbin thread tension should be adjusted so that the normal stitch can be obtained.

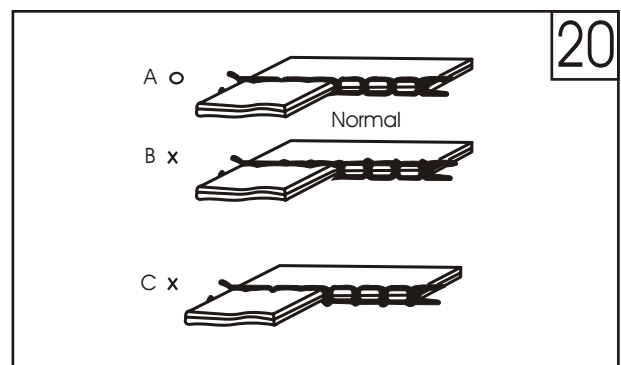

- a. If the stitch seam shows as Fig. 20B, indicates that the needle thread or bobbin thread tension is too loose, then turn the thread tension screw counter-clockwise to release the needle thread pressure; or turn the adjusting screw with a screwdriver to increase the bobbin thread tension. (see Fig.20,22)

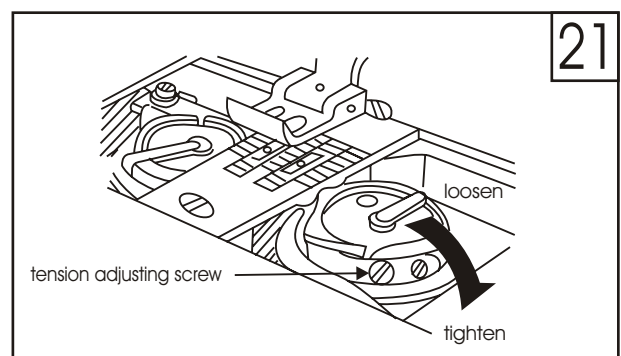

- b. If the needle thread is too loose and the bobbin thread is too tight, then shows as Fig. 20C, And turn the thread tension screw clockwise to increase the needle thread tension; or turn loose the bobbin lace screw to reduce the bobbin thread tension. (See Fig. 21, 22)

For special sewing with special thread, the tension needed can be obtained by adjusting the power and stroke of the thread take-up spring.

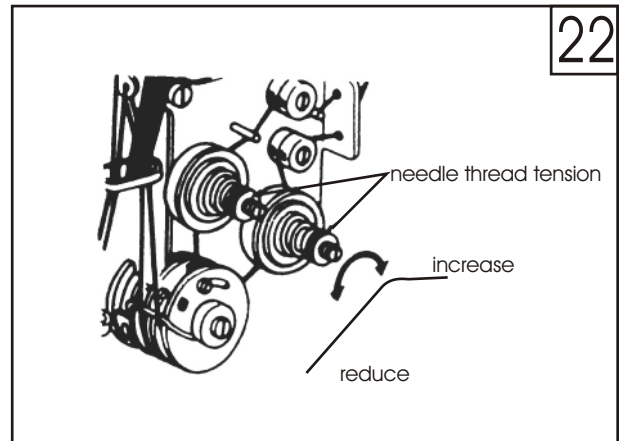

5.2 Adjusting the pressure of presser foot (Fig.23)

The pressure of the presser foot should be adjusted according to the thickness of the sewing materials. If stitch on heavy duty material, the pressure should be increased and turn the pressure adjusting screw on the back of the arm clockwise if reduce the pressure, turn it counter-clockwise.

5.3 Use and adjustment of the safety clutch device

The function of the safety clutch device is to prevent the hook and teeth-belt from destroy when the needle thread is drawn into the hook for adnormal load during the operation.

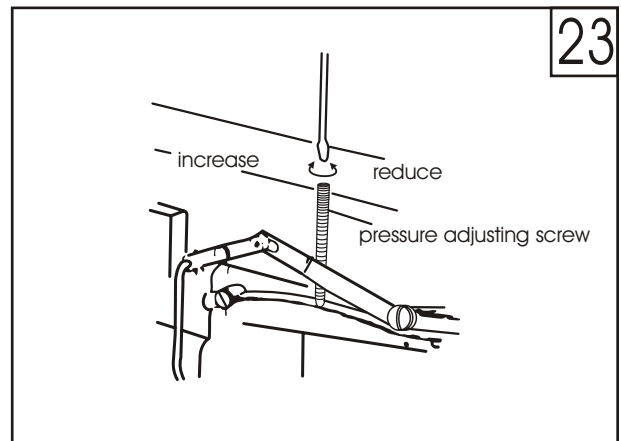

5.3.1 The function of the safety clutch device(Fig.24)

- When the safety clutch device is functioning, the teeth-belt will remove the load and the rock shaft will stop rotating, only the upper shaft rotates, and the machine stops work.
- Clean off the needle thread which is drawn in the hook.
- Turn the shaft of the teeth-belt with hand to check if the rock shaft can turn smoothly, then reset the safety clutch device.

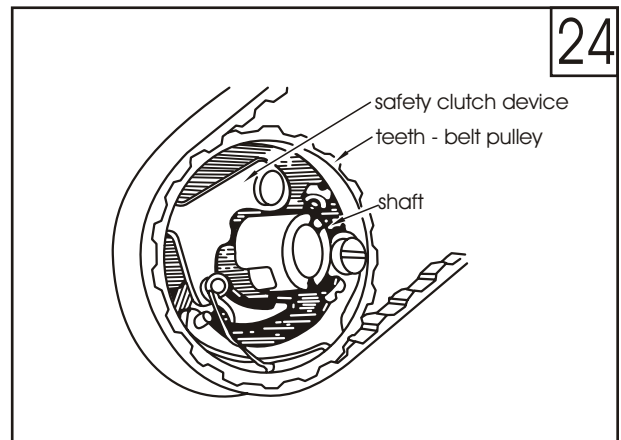

5.3.2 Resetting the safety clutch device.

- While press down the button in the bed surface with left hand, turn the balance wheel slowly with right hand in the direction shown in Fig. 25.

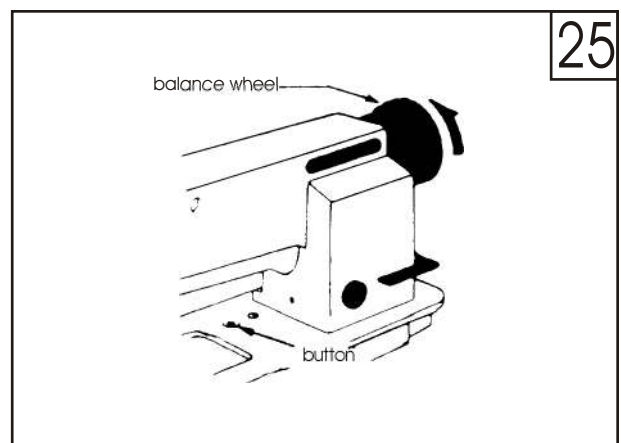

- b. When the stop plate stops the balance wheel, more strength is needed to turn the balance wheel to reset the safety clutch device.
- C. Release the button in the bed. So the resetting of it is OK. (See Fig.26)

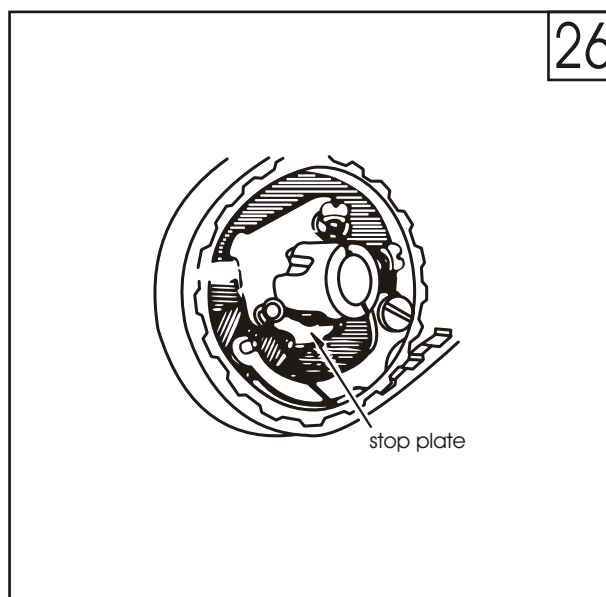

5.3.3 Regulating the strength on the safety clutch device(Fig.27)

- a. When the white mark of the eccentric pin aims at the center of the rock shaft, indicates that the strength on the safety clutch device is the minimum. When the white mark points outward, the strength is properly increased.
- b. For regulating the strength of it, move the teeth - belt and loosen the set screw of the eccentric pin, and turn the eccentric pin.
- c. After regulation, please tighten the set screw.

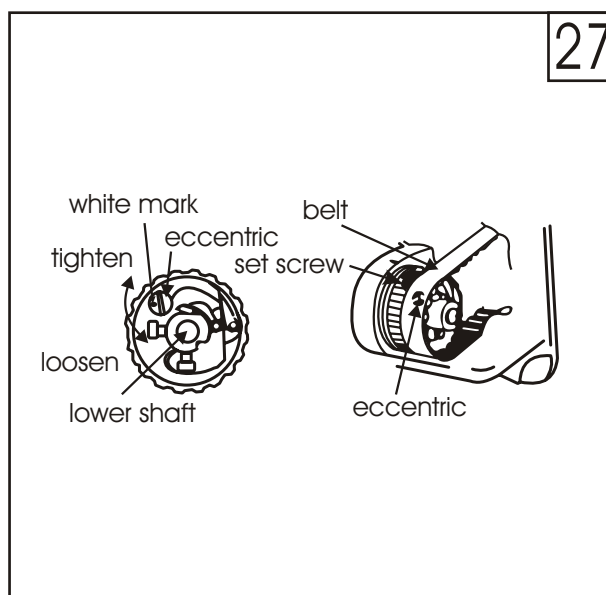

5.4 Upper feed adjustment (Fig.28)

If the upper and lower feed are not in timing during sewing, the long hole of the horizontal feed crank should be adjusted to get the length of upper feed.

Adjust as the following:

- a. Loosen the special screw.
- b. Move the special screw upward to reduce the feed amount or upper layer of material.
- c. Move the special screw downward to increase the feed amount. Theoretically when it is on the reference line of the horizontal feed crank, the upper feed amount equals to the lower feed amount.
- d. After adjustment, tighten the special screw.

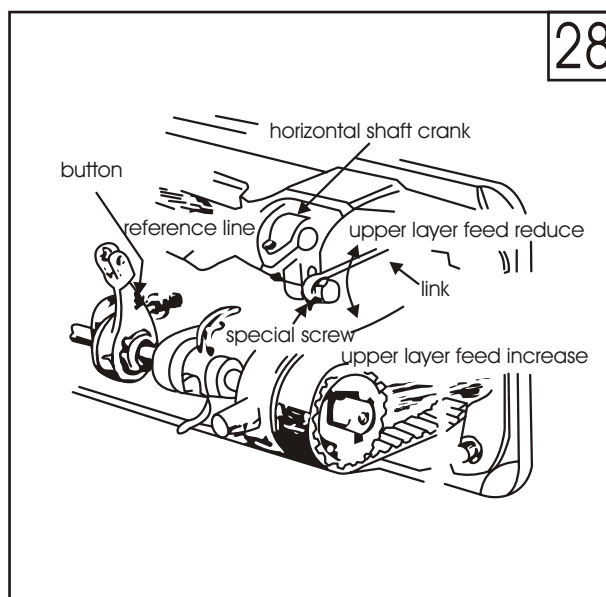

5.5 Presser foot lift volume adjustment (Fig.29)

when stitch on the very elastic material or the thickness of the sewing material is changed. The adjustment should be done in the following order:

1. Loosen the special screw.

2. When the centerline distance between the special screw and the presser foot lift rear crank becomes shorter, the presser foot lift volume will become longer. On the contrary the distance becomes longer, the lift volume will become shorter.

3. After adjustment, tighten the special screw. The common presser foot lift volume can be adjusted in the range of 2-6 mm.

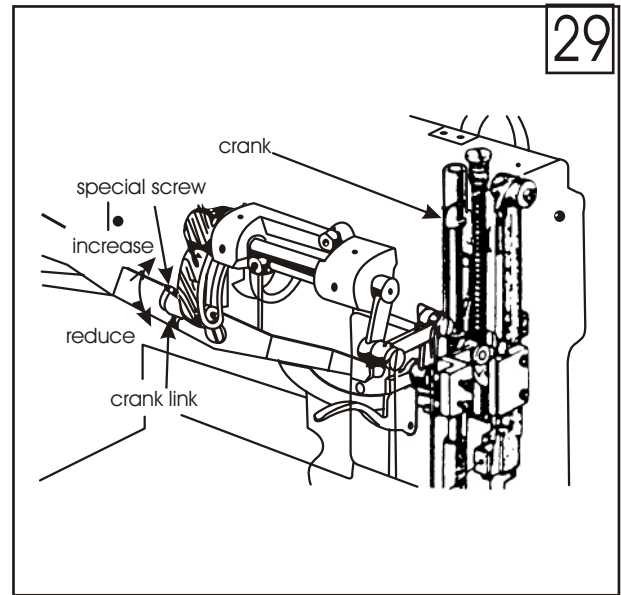

5.6 Hook oil amount adjustment (Fig.30)

It adopts plunger full auto lubrication system, even at very low speed, it can supply and suck oil very well. Generally only the hook oil amount can be adjusted, the other can not be adjusted. The hook oil amount can be obtained by the oil amount adjusting screw. First loosen the nut of the adjusting screw, turn the screw clockwise to increase the oil amount, on the contrary reduce the oil amount. After adjustment, tighten the nut.

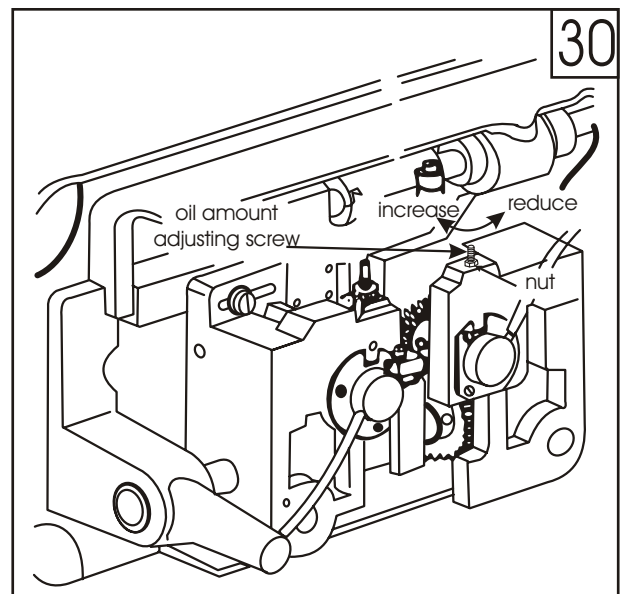

Parts Manual

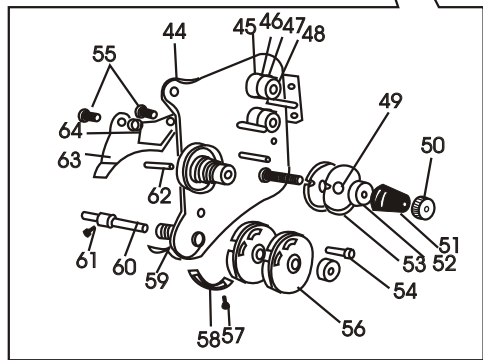
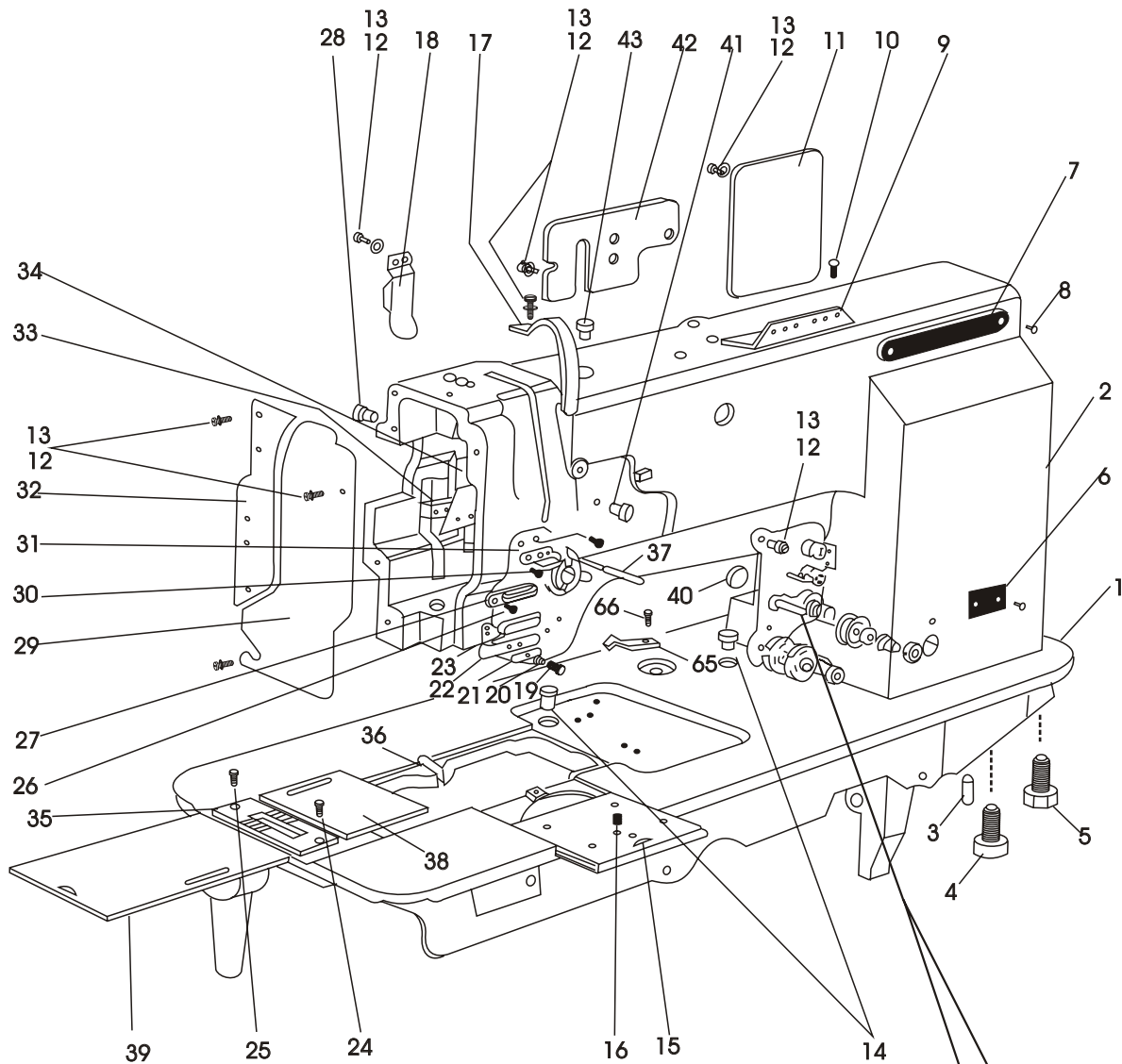

1. GC20606 Arm Parts

Item	Part number	Description	Pcs
1.	1WF1-001	Bed	1
2.	1WF1-002	Arm	1
3.		Pin	2
4.		Screw	1
5.		Screw	3
6.	1WF1-041	Trade mark plate	1
7.	1WF1-042	Model plate	1
8.		Nail	4
9.	1WF1-015	Upper thread guide	1
10.	1WF1-016	Screw	2
11.	1WF1-017	Back cover	1
12.	1WF1-011	Screw	15
13.		Washer	15
14.	1WF1-032	Cover	2
15.	1WF1-038	Front slide plate	1
16.	1WF1-039	Screw	1
17.	1WF1-019	Tread take-up lever guard	1
18.	1WF1-030	Back front cover	1
19..	1WF1-027	Screw	1
20.	1WF1-028	Spring	1
21.	1WF1-003	Thread retainer	1
22.	1WF1-004	Low thread figer	1
23.	1WF1-005	Screw	1
24.	1WF1-034	Screw	1
25.	1WF1-036	Screw	1
26.	1WF1-007	Screw	1
27.	1WF1-006	Middle thread finger	1
28.	1WF1-018	Rubber plug	2
29.	1WF1-013	Face plate	1
30.	1WF1-009	Screw	2
31.	1WF1-008	Upper thread finger	1

1

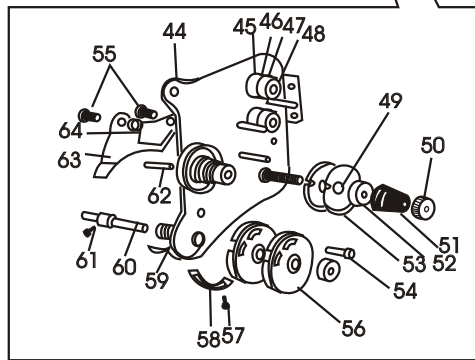
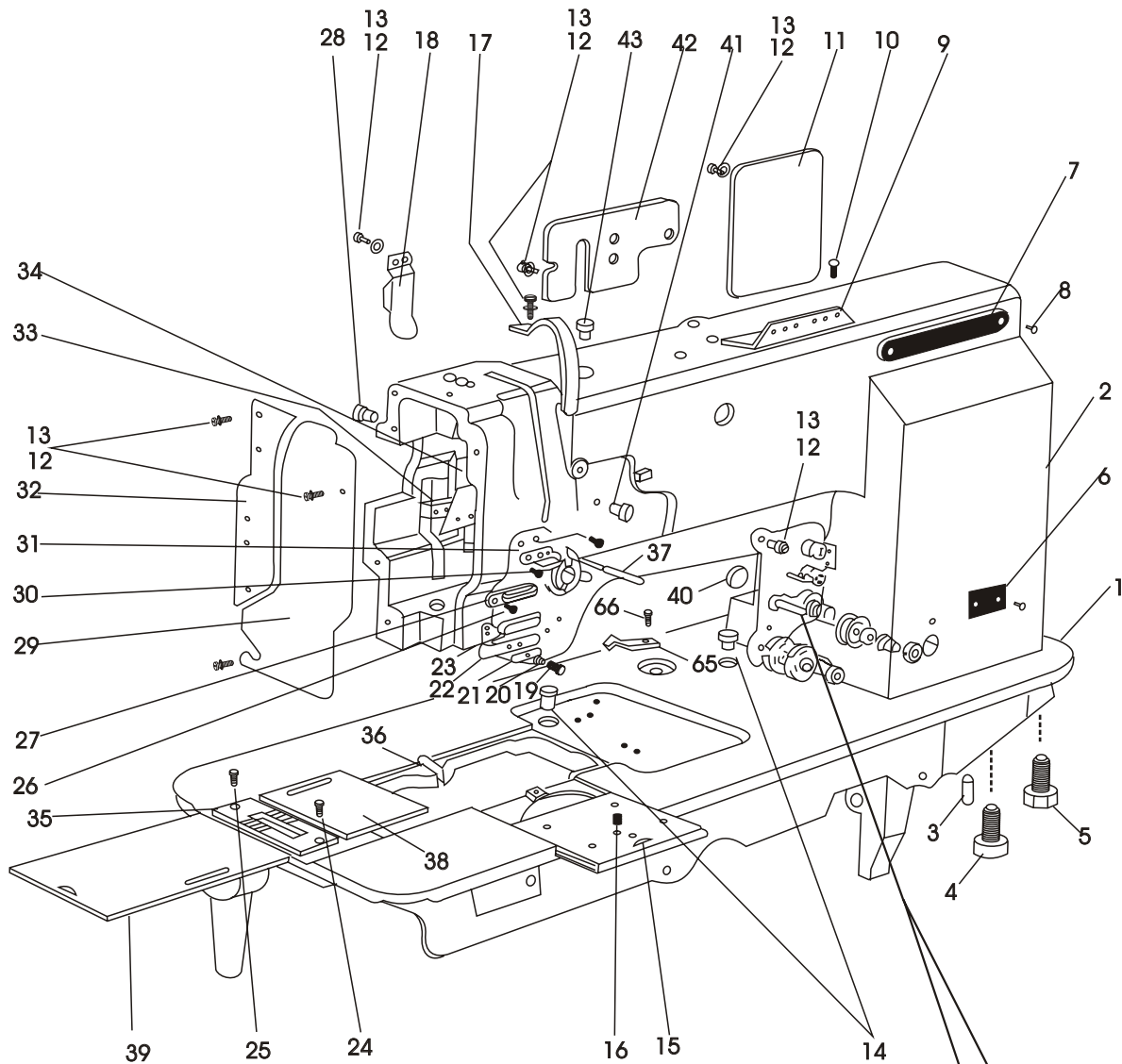

1. GC20606 Arm Parts

Item	Part number	Description	Pcs
32.	1WF1-012	Guid set plate	1
33.	1WF1-021	Set plate	1
34.	1WF1-020	Oil retainer	1
35.	1WF1-035	Tread releasing lever	1
36.	1WF1-037	Pin shaft	1
37.	1WF1-023	Thread releasing lever	1
38.	1WF1-033	Right sliding plate	1
39.	1WF1-040	Left sliding plate	1
40.	1WF1-029	Plug	1
41.	1WF1-022	Plug	1
42.	1WF1-031	Back fitting cover	1
43.	1WF1-014	Plug	1
44.	1WF1-010A	Tread tension set plate assembly	1
45.	1WF1-010B	Thread guide bracket	2
46.	1WF1-010C	Thread guide plate	2
47.	1WF1-010D	Spring	2
48.	1WF1-010E	Thread guide bracket screw assembly	2
49.	1WF1-010M	Tread releasing pin	1
50.	1WF1-010H	Tread tension nut	3
51.	1WF1-010G	Thread tension spring	2
52.	1WF1-010S	Thread tensing plate	2
53.	1WF1-010F	Thread tension plate	4
54.	1WF1-010R	Screw	1
55.	1WF1-010Q	Screw	2
56.	1WF1-010J	Thread control plate assembly	2
57.	1WF1-026	Screw	1
58.	1WF1-025	Stop plate	1
59.	1WF1-010K	Thread take-up spring	1
60.	1WF1-010I	Shaft for thread take-up spring	1
61.	1WF1-024	Set screw	1
62.	1WF1-010L	Thread releasing pin	1
63.	1WF1-010W	Thread tension retaining plate	1
64.	1WF1-010P	Thread releasing spring	1
65.	1WF1-043	Spring retaining plate	1
66.	22T2-004	Screw	1

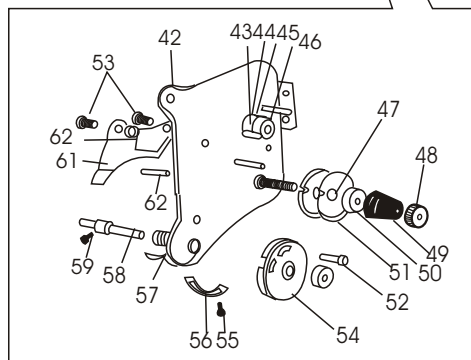
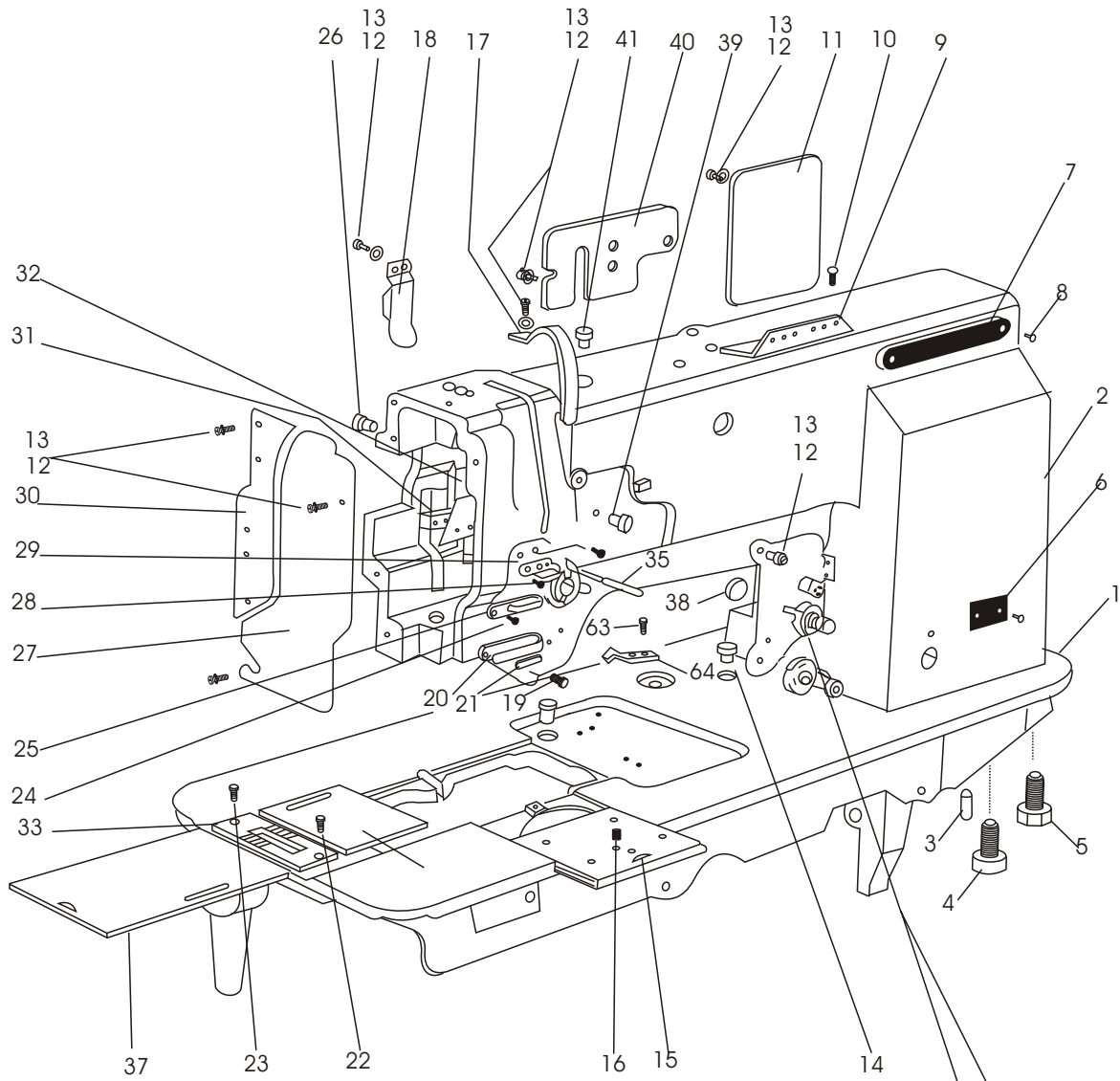

2. GC20606-1 Arm Parts

Item	Part number	Description	Pcs
1.	9WF1-007	Bed	1
2.	1WF1-002	Arm	1
3.		Pin	2
4.		Screw	1
5.		Screw	3
6.	9WF1-005	Trade mark plate	1
7.	9WF1-006	Modle plate	1
8.		Nail	4
9.	1WF1-015	Upper thread guide	1
10.	1WF1-016	Screw	2
11.	1WF1-017	Back cover	1
12.	1WF1-011	Screw	15
13.		Washer	15
14.	1WF1-032	Ccover	2
15.	1WF1-038	Front slide plate	1
16.	1WF1-039	Screw	1
17.	1WF1-019	Thread take-up lever guard	1
18.	1WF1-030	Back front cover	1
19..	1WF1-005	Screw	1
20.	9WF1-001	Low thread finger	1
21.	9WF1-002	Oil felt	1
22.	1WF1-034	Screw	1
23.	1WF1-036	Screw	1
24.	1WF1-007	Screw	1
25.	1WF1-006	Middle thread finger	1
26.	1WF1-018	Rubber plug	2
27.	1WF1-013	Face plate	1
28.	1WF1-009	Screw	2
29.	1WF1-008	Upper thread finger	1
30.	1WF1-012	Guide set plate	1
31.	1WF1-021	Set plate	1

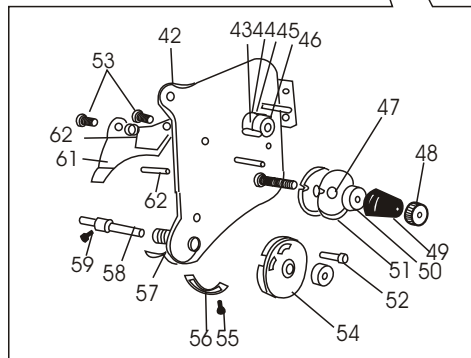
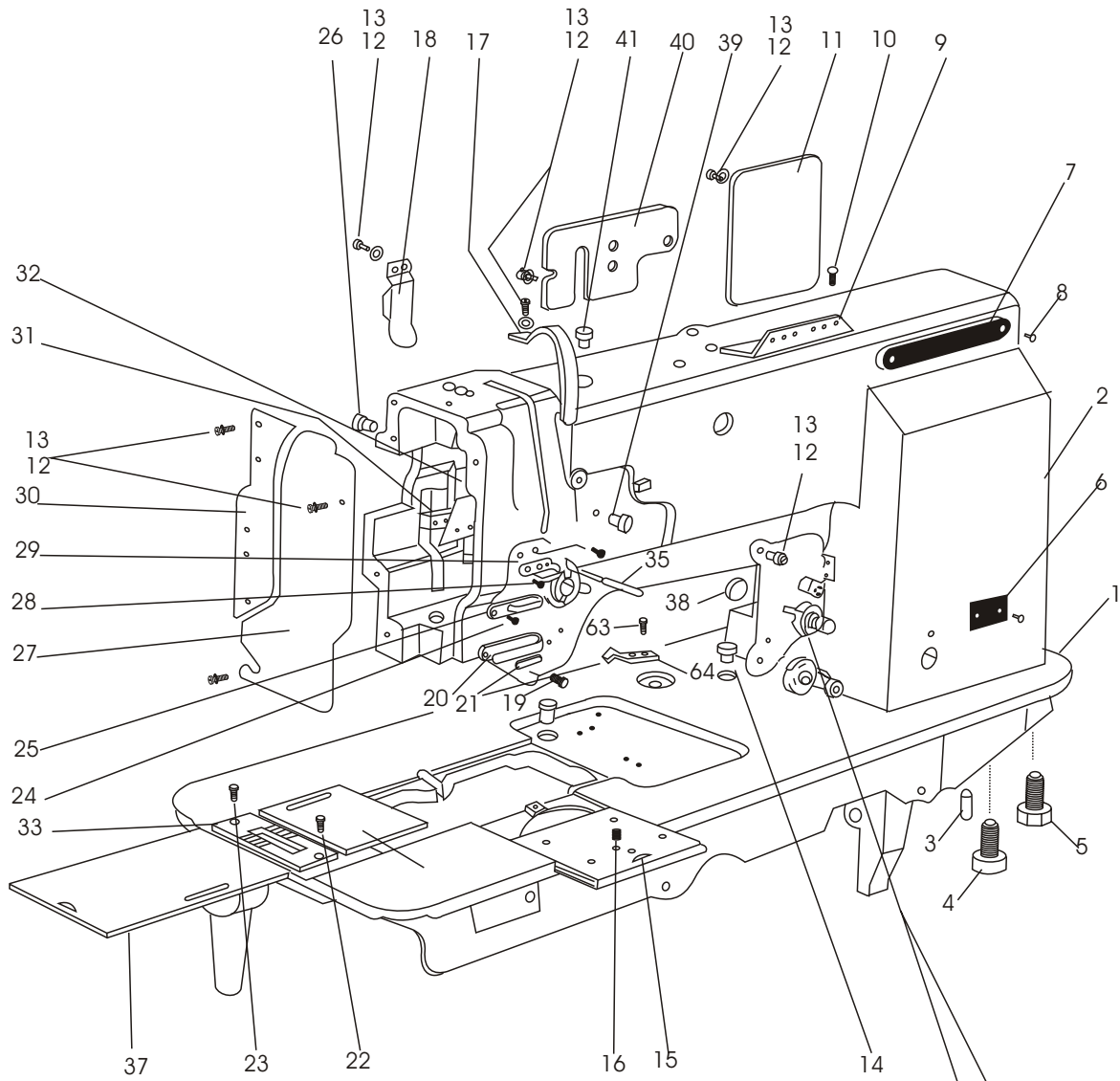

2. GC20606-1 Arm Parts

Item	Part number	Description	Pcs
32.	1WF1-020	Oil retainer	1
33.	9WF1-004A	Throat plate	1
34.	1WF1-043	Spring retaining plate	1
35.	1WF1-023	Thread releasing lever	1
36.	1WF1-033	Right sliding plate	1
37.	1WF1-040	Left sliding plate	1
38.	1WF1-029	Plug 14.5	1
39.	1WF1-022	Plug 12.7	1
40.	1WF1-031	Back fitting cover	1
41.	1WF1-034	Plug 12.7	1
42.	1WF1-010A	Thread tension set plate assembly	1
43.	1WF1-010B	Thread guide bracket	1
44.	1WF1-010C	Thread guide plate	1
45.	1WF1-010D	Spring	1
46.	1WF1-010E	Thread guide bracket screw assembly	1
47.	1WF1-010M	Thread releasing pin	1
48.	1WF1-010H	Thread tension nut	1
49.	1WF1-010G	Thread tension spring	1
50.	1WF1-010S	Thread releasing plate	1
51.	1WF1-010F	Thread tension plate	2
52.	1WF1-010R	Screw	1
53.	1WF1-010Q	Screw	2
54.	1WF1-010J	Thread control plate addembly	1
55.	1WF1-026	Screw	1
56.	1WF1-025	Stop plate	1
57.	1WF1-010K	Thread take-up spring	1
58.	1WF1-003A	Shaft for thread take-up spring	1
59.	1WF1-024	Set screw	1
60.	1WF1-010I	Thread releasing retaining plate	1
61.	1WF1-010W	Thread tension retaining plate	1
62.	1WF1-010P	Thread releasing spring	1
63.	22T2-004	Screw	1

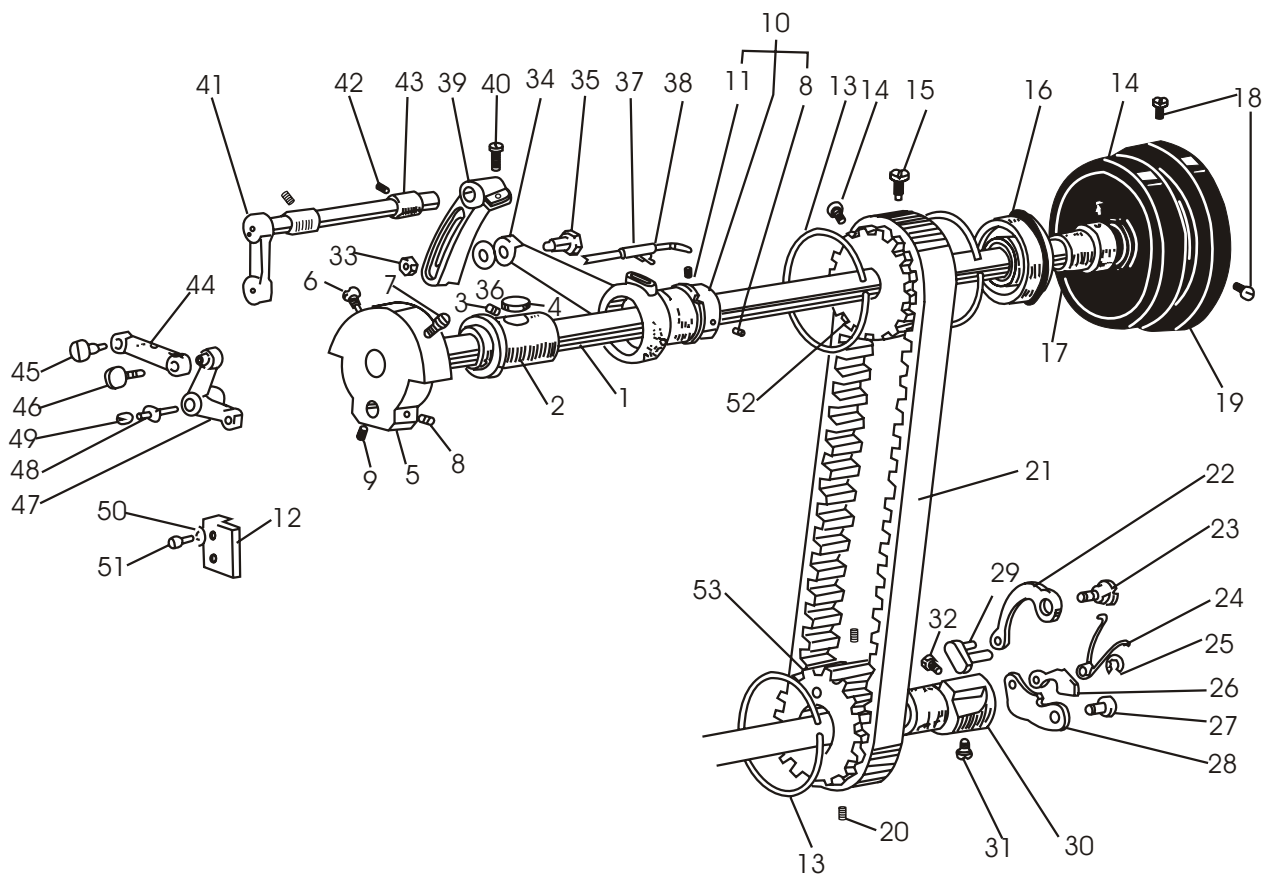

3. Upper Shaft Presser Foot Parts

Item	Part number	Description	Pcs
1.	1WF2-025	Upper shaft	1
2.	1WF2-022	Front bushing	1
3.	1WF2-023	Screw	1
4.	1WF2-024	Oil felt	1
5.	1WF2-021	Needle crank	1
6.	1WF2-020	Screw	1
7.	1WF2-007	Screw	1
8.	1WF2-010	Screw	3
9.	1WF2-009	Screw	1
10.	1WF5-026	Presser foot lift eccentric cam	1
11.		Stop ring	1
12.	1WF5-041	Slot for front crank sliding block	1
13.	1WF2-026	Stop ring	3
14.	1WF2-030	Screw	3
15.	1WF2-029	Set screw	1
16.		Ball bearing for upper shaft	1
17.	1WF2-031	Rear bushing for upper shaft	1
18.	1WF2-019	Screw	2
19.	1WF2-032	Balance wheel	1
20.	1WF2-044	Screw	2
21.	1WF2-028	Teeth belt	1
22.	1WF2-039	Spring plate	1
23.	1WF2-037	Pin for eccentric shaft	1
24.	1WF2-041	Spring	1
25.		Split stop ring	1
26.	1WF2-040	Stop plate	1
27.	1WF2-048	Nail	1
28.	1WF2-045	Control plate	1
29.	1WF2-042	Connection	1
30.	1WF2-046	Bushing	1
31.	1WF2-047	Set screw	1

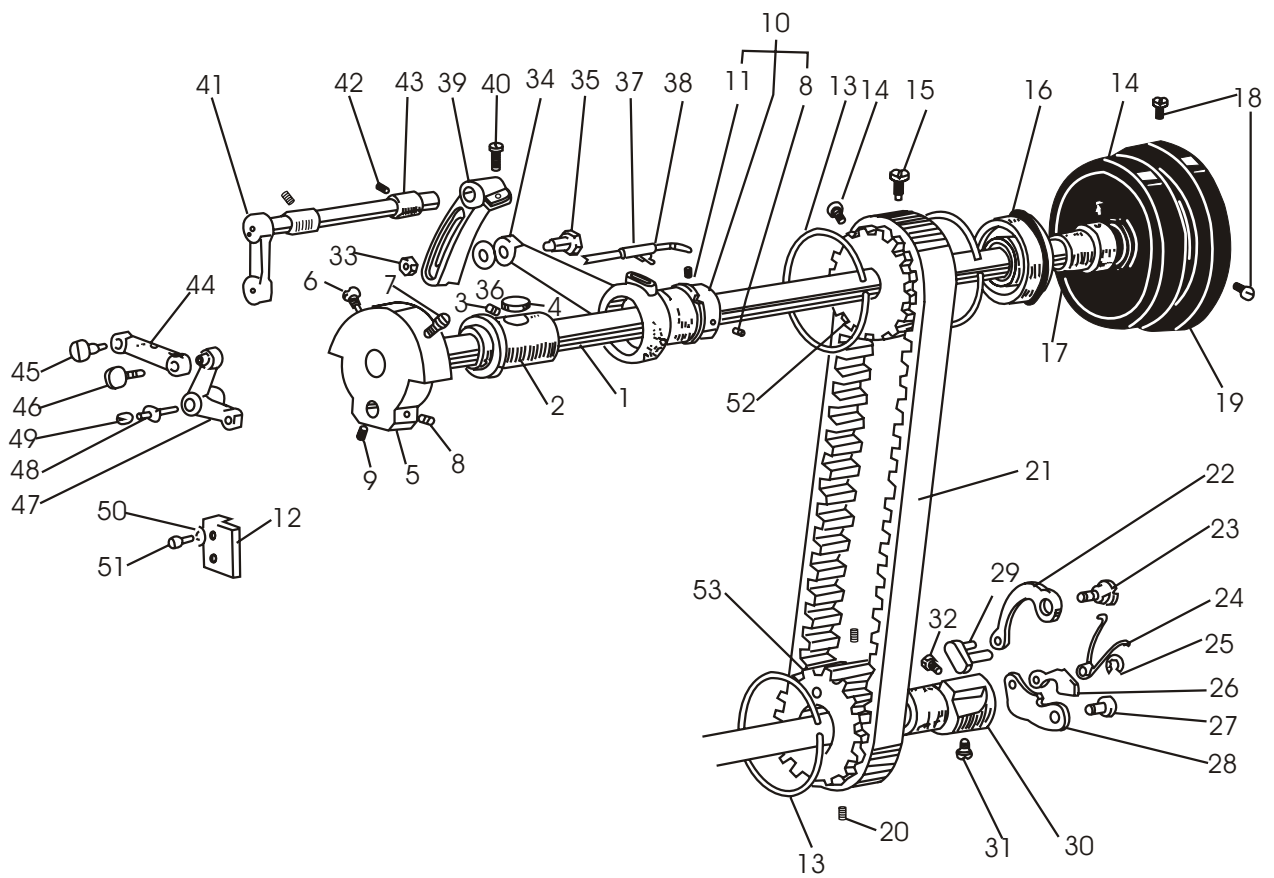

3. Upper Shaft Presser Foot Parts

Item	Part number	Description	Pcs
32.	1WF2-038	Screw	1
33.	1WF5-001	Nut	1
34.	1WF5-025	Connecting lever	1
35.	1WF5-044	Connecting screw	1
36.		Washer	1
37.	1WF5-023	Oil tube assembly	1
38.	1WF5-024	Spring	1
39.	1WF5-045	Presser foot lift rear crank	1
40.	1WF4-018	Screw	3
41.	1WF5-038	Presser foot lift front crank	1
42.	1WF5-028	Screw	2
43.	1WF5-037	Bushing	2
44.	1WF5-030	Presser foot lift link	1
45.	1WF5-029	Connecting screw	1
46.	1WF5-032	Connecting screw	1
47.	1WF5-033	Presser foot lift movable plate	1
48.	1WF5-034	Shaft for needle bearing	1
49.	1WF5-035	Needle bearing	1
50.		Washer	1
51.	1WF5-042	Screw	2
52.	1WF2-027	Timing wheel	2
53.	1WF2-037	Timing wheel	1

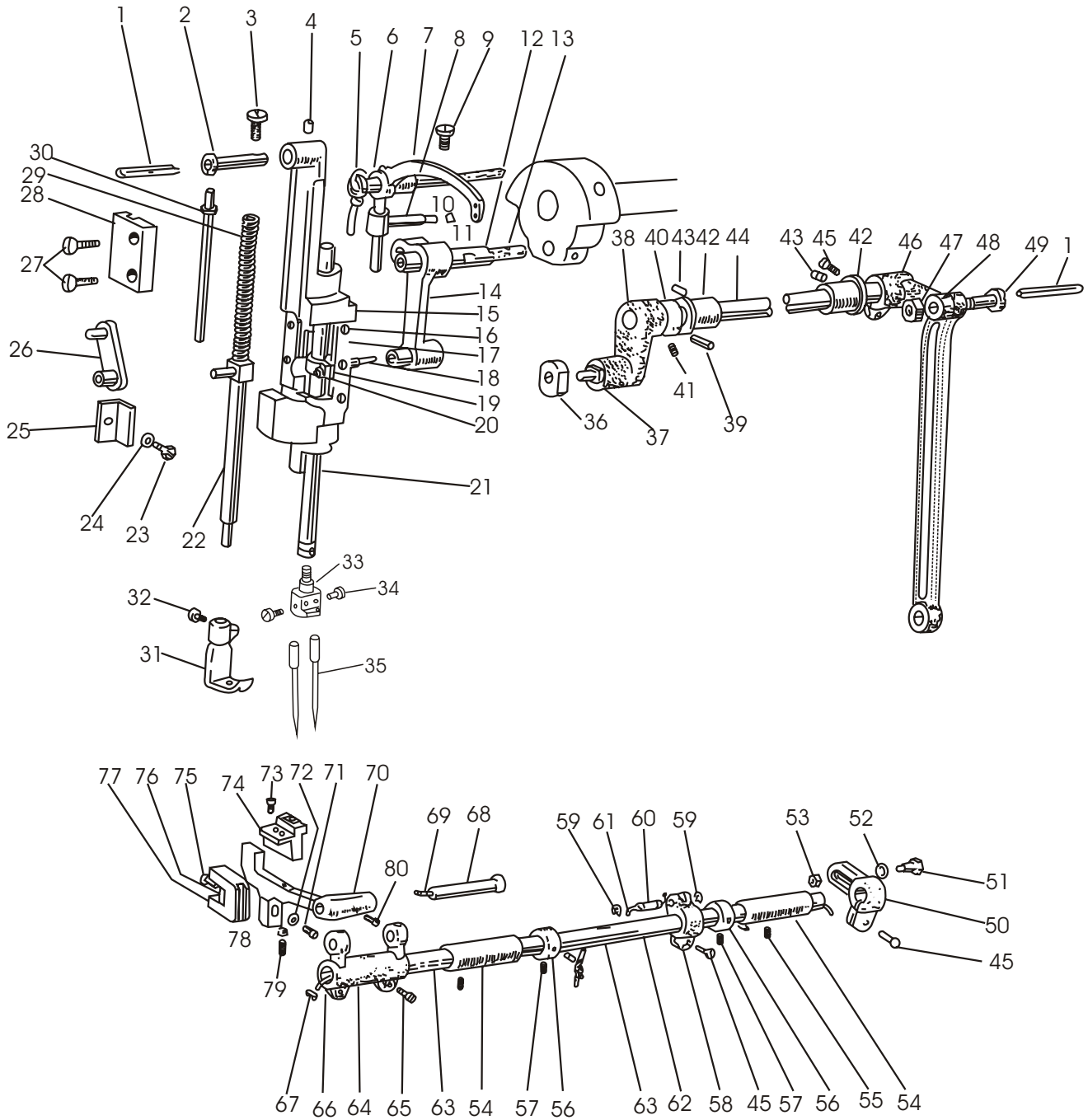

4. GC20606 Needle Bar And Lower Feed Parts

Item	Part number	Description	Pcs
1.	1WF5-017	Oil wick	2
2.	1WF5-018	Shaft for needle bar motion holder	1
3.	1WF5-031	Screw	1
4.	1WF5-019	Screw	1
5.	1WF2-018	Oil wick	1
6.	1WF2-017	Bushing for thread take-up lever hole	1
7.	1WF2-016	Thread take-up lever	1
8.	1WF2-011	Sliding block	1
9.	1WF2-019	Screw	1
10.	1WF2-012	Oil wick	1
11.	1WF2-013	Plug	1
12.	1WF2-014	Pin for needle bar crank	1
13.	1WF2-015	Oil wick	1
14.	1WF2-008	Needle bar link	1
15.	1WF5-011	Needle bar motion holder	1
16.	1WF5-013	Screw	6
17.	1WF5-012	Shim for needle bar motion holder	2
18.	1WF2-007	Oil felt	1
19.	1WF2-005	Needle bar adaptor	1
20.	1WF2-006	Screw	1
21.	1WF2-004	Needle bar	1
22.	1WF5-006	Presser bar	1
23.	1WF5-010	Screw	1
24.		Washer	1
25.	1WF5-009	Needle bar holder guide	1
26.	1WF5-036	Presser bar link	1
27.	1WF3-009	Screw	2
28.	1WF5-014	Needle bar motion holder guide	1
29.	1WF5-016	Spring	1
30.	1WF5-015	Reel for spring	1
31.	1WF5-043	Alternate foot	1
32.	22T2-004	Screw	1
33.	1WF2-003	Needle holder	1
34.	1WF2-002	Screw	2
35.	1F-009	Needle	2
36.	1WF5-007	Sliding block for needle bar motion	1
37.	1WF5-008	Shaft for sliding block	1
38.	1WF5-020	Left crank	1
39.		Pin	1
40.	1WF5-021	Washer	1
41.	1WF5-022	Screw	2

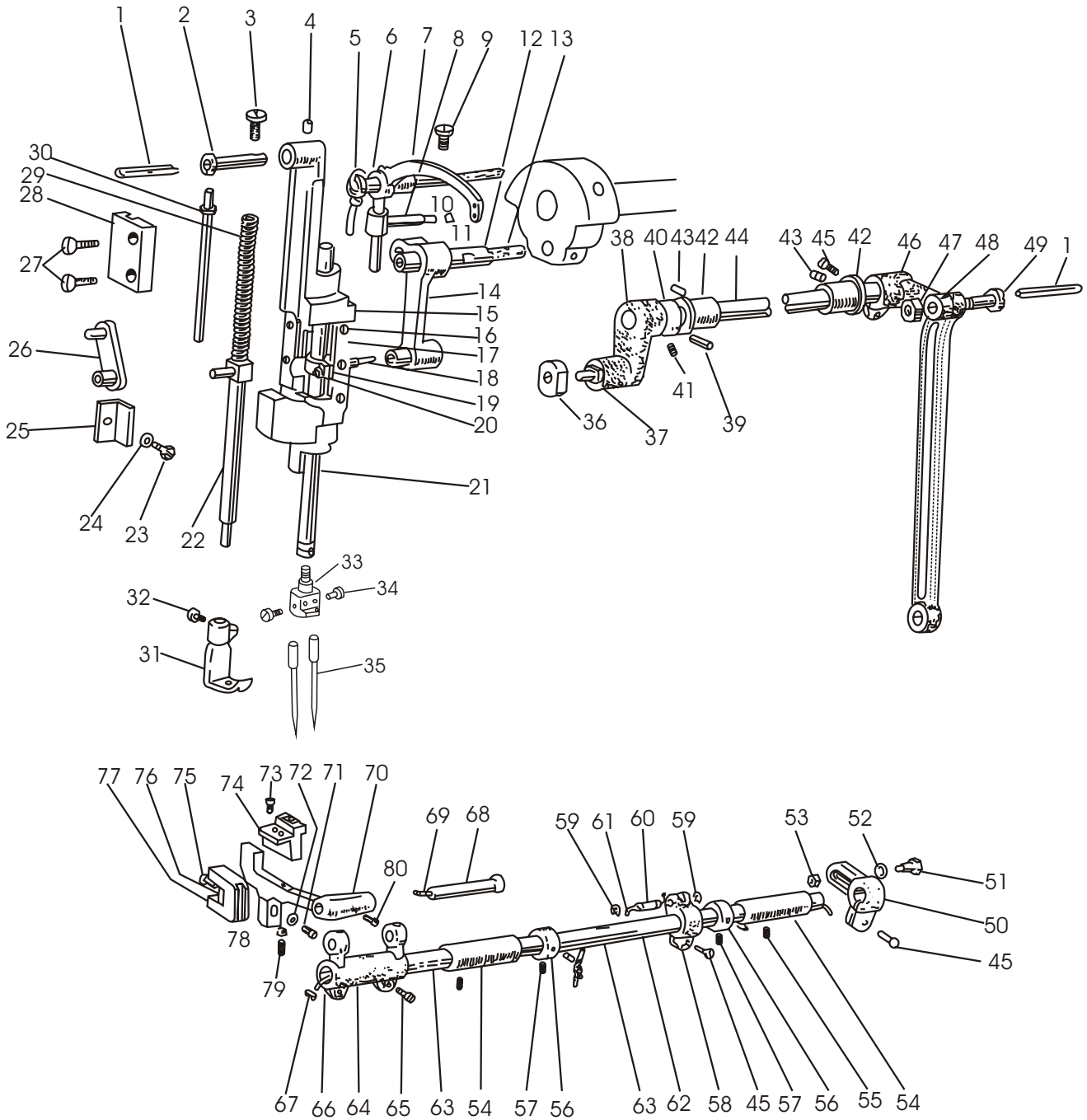

4. GC20606 Needle Bar And Lower Feed Parts

Item	Part number	Description	Pcs
42.	1WF5-027	Bushing for needle bar motion shaft	2
43.	1WF5-028	Set screw	2
44.	1WF5-048	Shaft for needle bar motion	1
45.	1WF4-018	Screw	3
46.	1WF5-005	Rear crank for needle bar motion	1
47.	1WF5-004	Connecting nut	1
48.	1WF5-003	Link for needle bar motion	1
49.	1WF5-049	Connecting screw	1
50.	1WF5-002	Right crank for feed shaft	1
51.	1WF5-046	Pin for right crank	1
52.	1WF5-047	Washer	1
53.	1WF5-001	Nut	1
54.	1WF4-052	Feed shaft bushing	2
55.	1WF2-023	Set screw	2
56.	1WF4-054	Collar for feed shaft	2
57.	1WF2-009	Screw	4
58.	41WF3-017	Feed crank	1
59.		Split stop ring	2
60.	1WF4-019	Pin for feed crank	1
61.	1WF4-020	Oil wick	1
62.	1WF4-037	Feed shaft	1
63.	1WF4-038	Oil felt	2
64.	1WF4-035	Feed connecting crank(left)	1
65.	1WF4-034	Tension screw	2
66.	1WF4-029	Oil wick clump	1
67.	1WF4-030	Oil wick	1
68.	1WF4-036	Shaft for feet dog support crank	1
69.	1WF4-031	Oil wick	1
70.	9WF4-001	Feed dog support	1
71.	1WF4-032	Connecting screw	1
72.		Washer	1
73.	1WF4 -005	Screw	2
74.	1WF4-004	Feed dog	1
75.	1WF4-007	Screw	1
76.	1WF4-008	Oil felt for feed dog lift fork	1
77.	1WF4-009	Feed dog lift fork	1
78.	1WF4-002	Nut	1
79.	1WF4-003	Feed dog adjusting screw	1
80.	1WF4-033	Screw	1

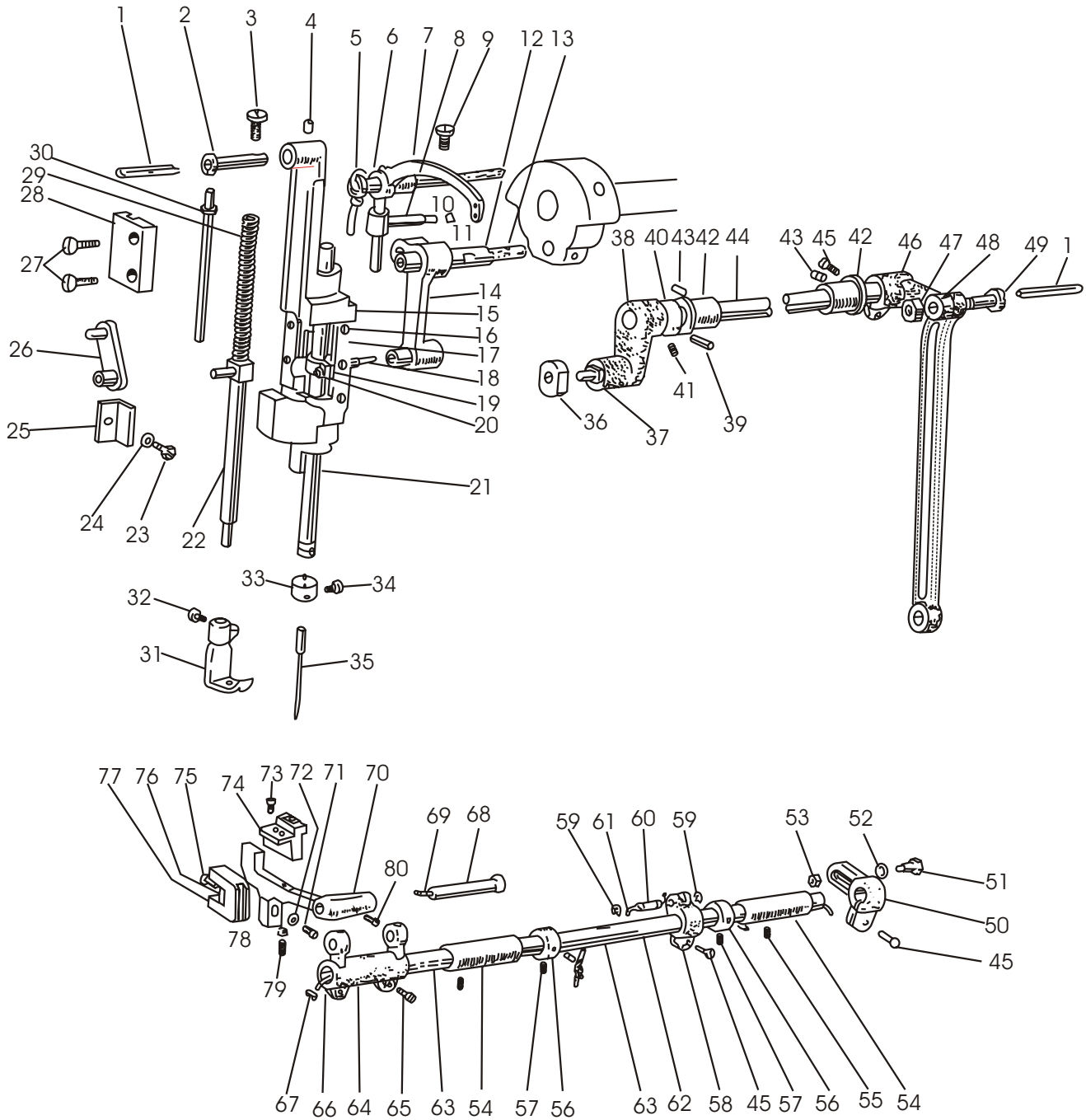

5. GC20606-1 Needle Bar And Lower Feed Parts

Item	Part number	Description	Pcs
1.	1WF5-017	Oil wick	2
2.	1WF5-018	Shaft for needle bar motion holder	1
3.	1WF5-031	Screw	1
4.	1WF5-019	Screw	1
5.	1WF2-018	Oil wick	1
6.	1WF2-017	Bushing for thread take-up lever hole	1
7.	1WF2-016	Thread take-up lever	1
8.	1WF2-011	Sliding block	1
9.	1WF2-019	Screw	1
10.	1WF2-012	Oil wick	1
11.	1WF2-013	Plug	1
12.	1WF2-014	Pin for needle bar crank	1
13.	1WF2-015	Oil wick	1
14.	1WF2-008	Needle bar link	1
15.	1WF5-011	Needle bar motion holder	1
16.	1WF5-013	Screw	6
17.	1WF5-012	Shim for needle bar motion holder	2
18.	1WF2-007	Oil felt	1
19.	1WF2-005	Needle bar adaptor	1
20.	1WF2-006	Screw	1
21.	1WF2-001	Needle bar	1
22.	1WF5-006	Presser bar link	1
23.	1WF5-010	Screw	1
24.	22T1-007	Washer	1
25.	1WF5-009	Needle bar holder guide	1
26.	1WF5-036	Presser bar link	1
27.	1WF3-009	Screw	2
28.	1WF5-014	Needle bar motion holder guide	1
29.	1WF5-016	Spring	1
30.	1WF5-015	Reel for spring	1
31.	35T5-502	Alternate foot	1
32.	22T2-004	Screw	1
33.	35T1-103	Thread guide ring	1
34.	22T2-017	Screw	1
35.	1F-009	Needle	1
36.	1WF5-007	Sliding block for needle bar motion	1
37.	1WF5-008	Shaft for sliding block	1
38.	1WF5-020	Left crank	1
39.		Pin	1
40.	1WF5-021	Washer	1
41.	1WF5-022	Screw	2

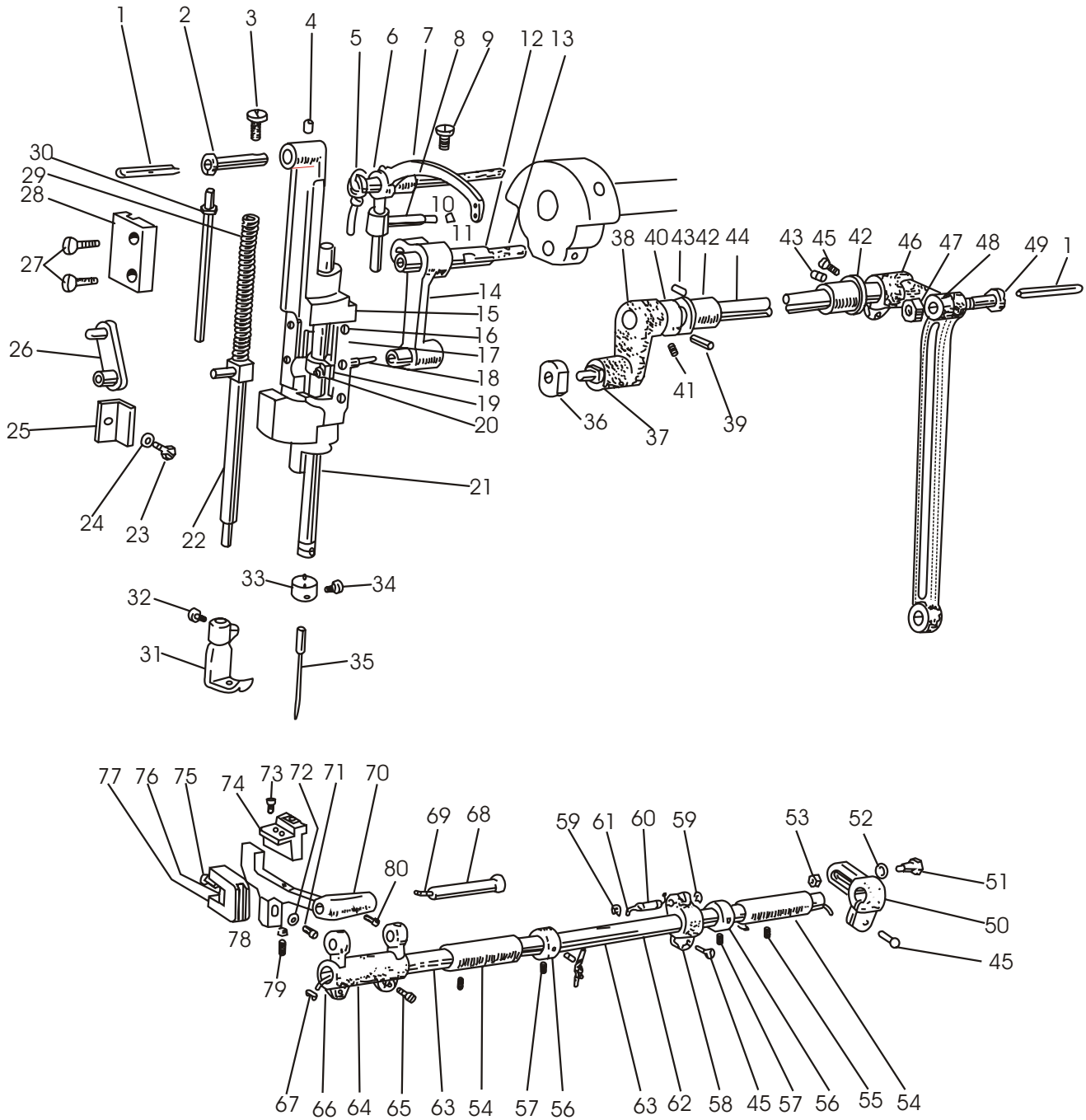

5. GC20606-1 Needle Bar And Lower Feed Parts

Item	Part number	Description	Pcs
42.	1WF5-027	Bushing for needle bar motion shaft	2
43.	1WF5-028	Set screw	2
44.	1WF5-048	Shaft for needle bar motion	1
45.	1WF4-018	Screw	3
46.	1WF5-005	Rear crank for needle bar motion	1
47.	1WF5-004	Connecting nut	1
48.	1WF5-003	Link for needle bar motion	1
49.	1WF5-049	Connecting screw	1
50.	1WF5-002	Right crank for feed shaft	1
51.	1WF5-046	Pin for right crank	1
52.	1WF5-047	Washer	1
53.	1WF5-001	Nut	1
54.	1WF4-052	Feed shaft bushing	2
55.	1WF2-023	Set screw	2
56.	1WF4-054	Collar for feed shaft	2
57.	1WF2-009	Screw	4
58.	41WF3-016	Feed crank	1
59.		Split stop ring	2
60.	1WF4-019	Pin for feed crank	1
61.	1WF4-020	Oil wick	1
62.	1WF4-037	Feed shaft	1
63.	1WF4-038	Oil felt	2
64.	1WF4-035	Feed connecting crank(left)	1
65.	1WF4-034	Tension screw	2
66.	1WF4-030	Oil wick clump	1
67.	1WF4-029	Oil wick	1
68.	1WF4-036	Shaft for feed dog support crank	1
69.	1WF4-031	Oil wick	1
70.	9WF4-001	Feed dog support	1
71.	1WF4-032	Connecting screw	1
72.		Washer	1
73.		Screw	2
74.	9WF4-002A	Feed dog	1
75.	1WF4-007	Screw	1
76.	1WF4-008	Oil felt for feed dog lift fork	1
77.	1WF4-009	Feed dog lift fork	1
78.	1WF4-002	Nut	1
79.	1WF4-003	Feed dog adjusting screw	1
80.	1WF4-033	Screw	1

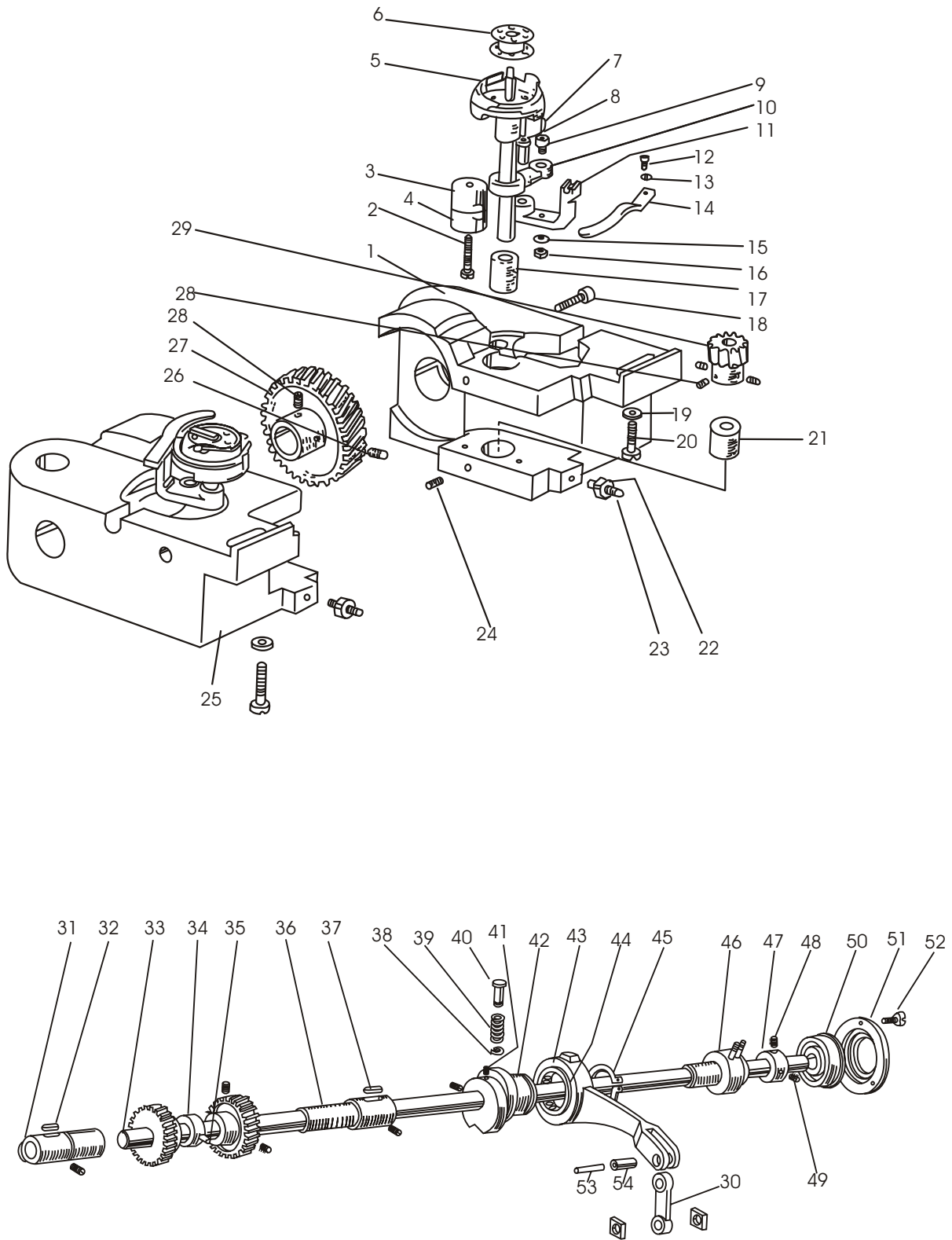

6. GC20606 Rock Shaft And Thread Looping Parts

Item	Part number	Description	Pcs
1.	1WF2-063	Right hook saddle	1
2.	1WF2-060	Screw	2
3.	1WF2-059	Upper bushing of hook saddle	2
4.	1WF2-061	Lower bushing of hook saddle	2
5.	1WF2-064	Hook assembly	2
6.	1WF2-065	Bobbin	2
7.	1WF2-070	Oil wick	2
8.	1WF2--069	Hinge shaft	2
9.	1WF2-072	Screw	2
10.	1WF2-071	Connecting lever	2
11.	1WF2-075	Thread finger bracket	2
12.	1WF5-026	Screw	2
13.		Washer	2
14.	1WF2-076	Thread finger	2
15.		Springy washer	2
16.	1WF2-074	Nut	2
17.	1WF2-062	Bushing	2
18.	1WF2-034	Set screw	2
19..		Washer	2
20.	1WF2-033	Tension screw for hook saddle	2
21.	1WF2-077	Bushing	2
22.	1WF2-067	Adjusting nut	2
23.	1WF2-066	Adjusting screw	2
24.	1WF2-044	Screw	2
25.	1WF2-068	Left hook saddle	1
26.	1WF2-052	Screw	2
27.	1WF2-078	Spiral gear	2
28.	1WF2-009	Screw	8
29.	1WF2-079	Spiral gear	2
30.	1WF2-055	Feed link	1
31.	1WF2-035	Left bushing for rock shaft	1

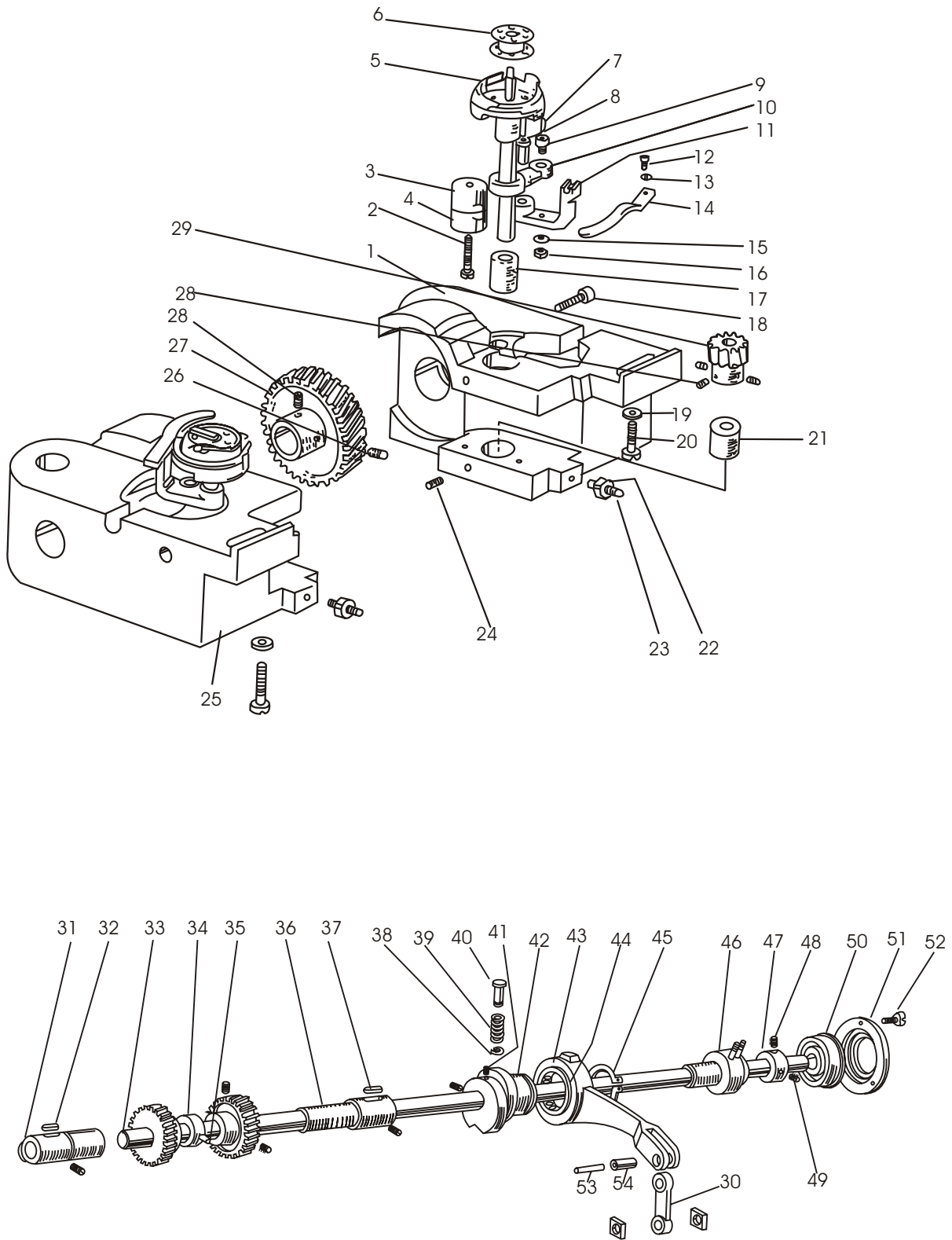

6. GC20606 Rock Shaft And Thread Looping Parts

Item	Part number	Description	Pcs
32.	1WF2-036	Oil wick	1
33.	1WF2-056	Rock shaft	1
34.	1WF2-006	Feed dog lift cam	1
35.	1WF2-019	Set screw	1
36.	1WF2-057	Right bushing for rock shaft	1
37.	1WF2-058	Oil wick	1
38.		Split stop ring	1
39.	1WF4-041	Spring	1
40.	1WF4-042	Button	2
41.	1WF4-010	Set screw	1
42.	1WF4-011	Feed cam	1
43.	1WF4-012	Feed link	1
44.		Needle bearing	1
45.		Spring stop ring	1
46.	1WF2-055	Middle bushing assembly for rock shaft	1
47.	1WF2-051	Rear bushing for rock shaft	1
48.	1WF2-009	Screw	1
49.	1WF2-052	Set screw	1
50.		Ball bearing for rock shaft	1
51.	1WF2-050	Bearing press ring	3
52.	1WF2-049	Set screw	1
53.	1WF4-044	Oil wick	1
54.	1WF4-043	Feed link pin	1

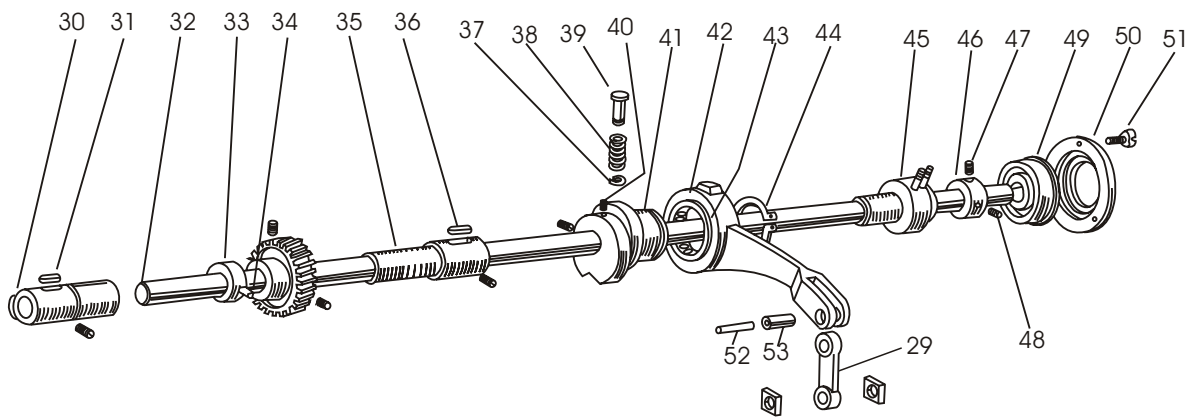
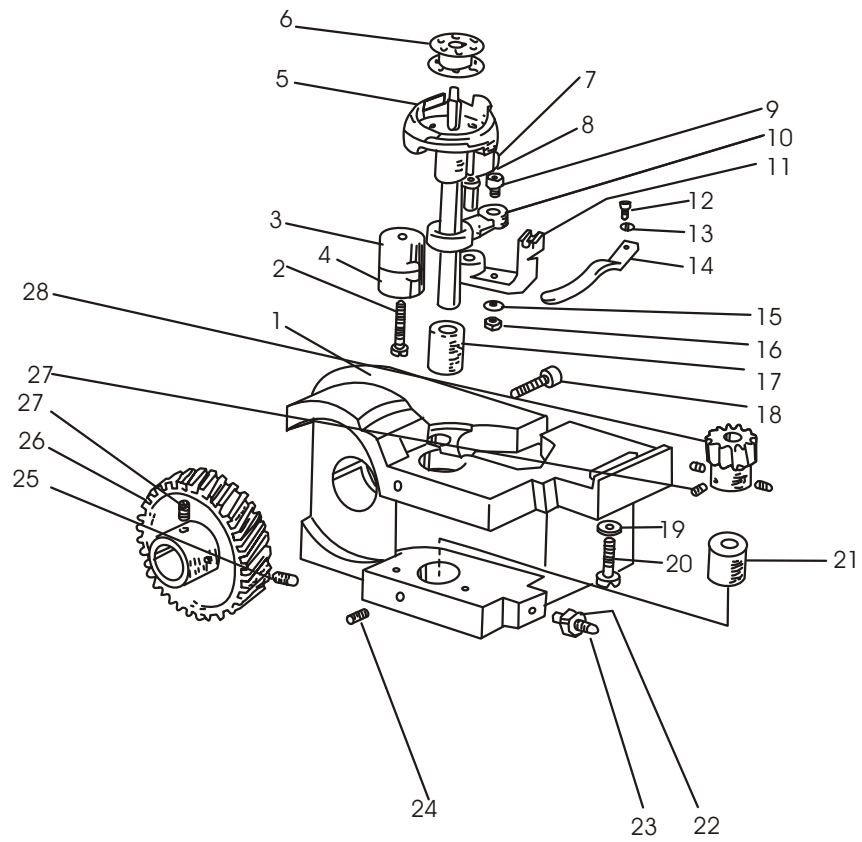

7.GC20606-1 Rock Shaft And Thread Looping Parts

Item	Part number	Description	Pcs
1.	1WF2-063	Right hook saddle	1
2.	1WF2-060	Screw	1
3.	1WF2-059	Upper bushing of hook saddle	1
4.	1WF2-061	Lower bushing of hook saddle	1
5.	1WF2-064	Hook assembly	1
6.	1WF2-065	Bobbin	1
7.	1WF2-070	Oil wick	1
8.	1WF2--069	Hinge shaft	1
9.	1WF2-072	Screw	1
10.	1WF2-071	Connecting lever	1
11.	1WF2-075	Thread finger bracket	1
12.	1WF5-026	Screw	1
13.		Washer	1
14.	1WF2-076	Thread finger	1
15.		Springy washer	1
16.	1WF2-074	Nut	1
17.	1WF2-062	Bushing	1
18.	1WF2-034	Set screw	1
19.		Washer	1
20.	1WF2-033	Tension screw for hook saddle	1
21.	1WF2-077	Bushing	1
22.	1WF2-067	Adjusting nut	1
23.	1WF2-066	Adjusting screw	1
24.	1WF2-044	Screw	1
25.	1WF2-052	Screw	1
26.	1WF2-078	Spiral gear	1
27.	1WF2-009	Screw	4
28.	1WF2-079	Spiral gear	2
29.	1WF2-055	Feed link	1
30.	1WF2-035	Left bushing for rock shaft	1
31.	1WF2-036	Oil wick	1

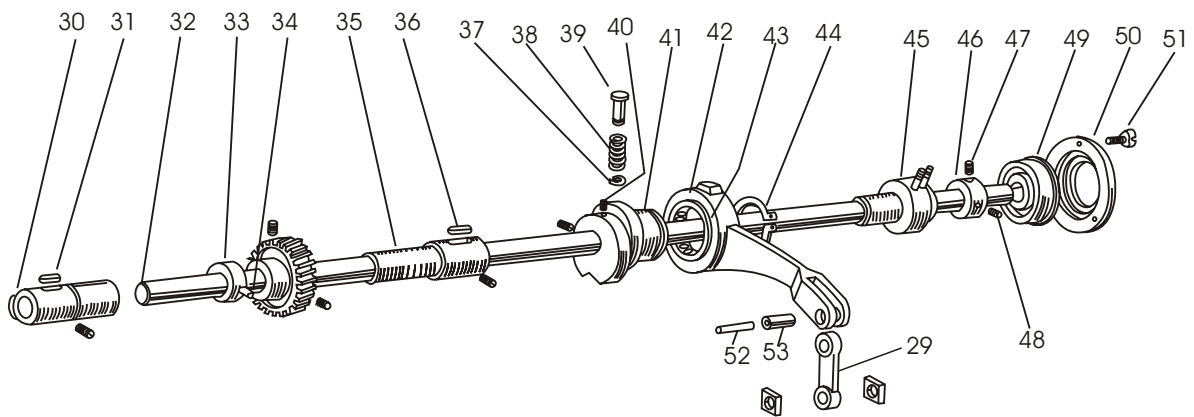
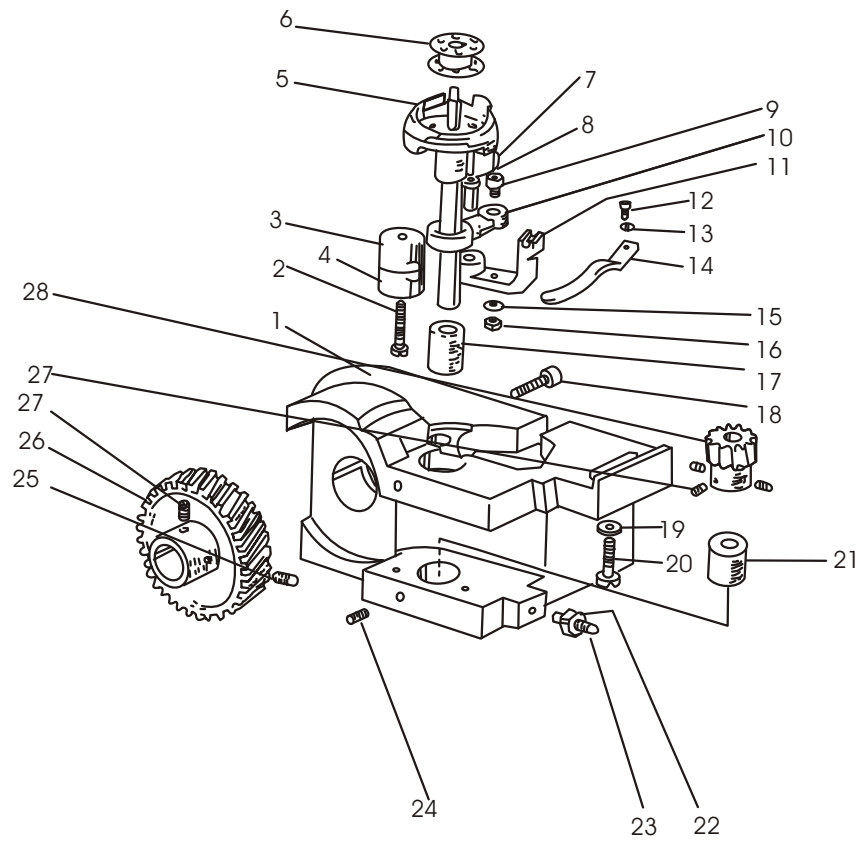

7.GC20606-1 Rock Shaft And Thread Looping Parts

Item	Part number	Description	Pcs
32.	1WF2-056	Rock shaft	1
33.	1WF2-006	Feed dog lift cam	1
34.	1WF2-019	Set screw	1
35.	1WF2-057	Right bushing for rock shaft	1
36.	1WF2-058	Oil wick	1
37.		Split stop ring	1
38.	1WF2-041	Spring	1
39.	1WF4-0421WF4-042	Button	1
40.	1WF4-010	Set screw	2
41.	1WF4-011	Feed cam	1
42.	1WF4-012	Feed link	1
43.		Needle bearing	1
44.		Spring stop ring	1
45.	1WF2-055	Middle bushing assembly for rock shaft	1
46.	1WF2-051	Rear bushing for rock shaft	1
47.	1WF2-009	Screw	1
48.	1WF2-052	Set screw	1
49.		Ball bearing for rock shaft	1
50.	1WF2-050	Bearing press ring	1
51.	1WF2-049	Set screw	3
52.	1WF4-044	Oil wick	1
53.	1WF4-043	Feed link pin	1

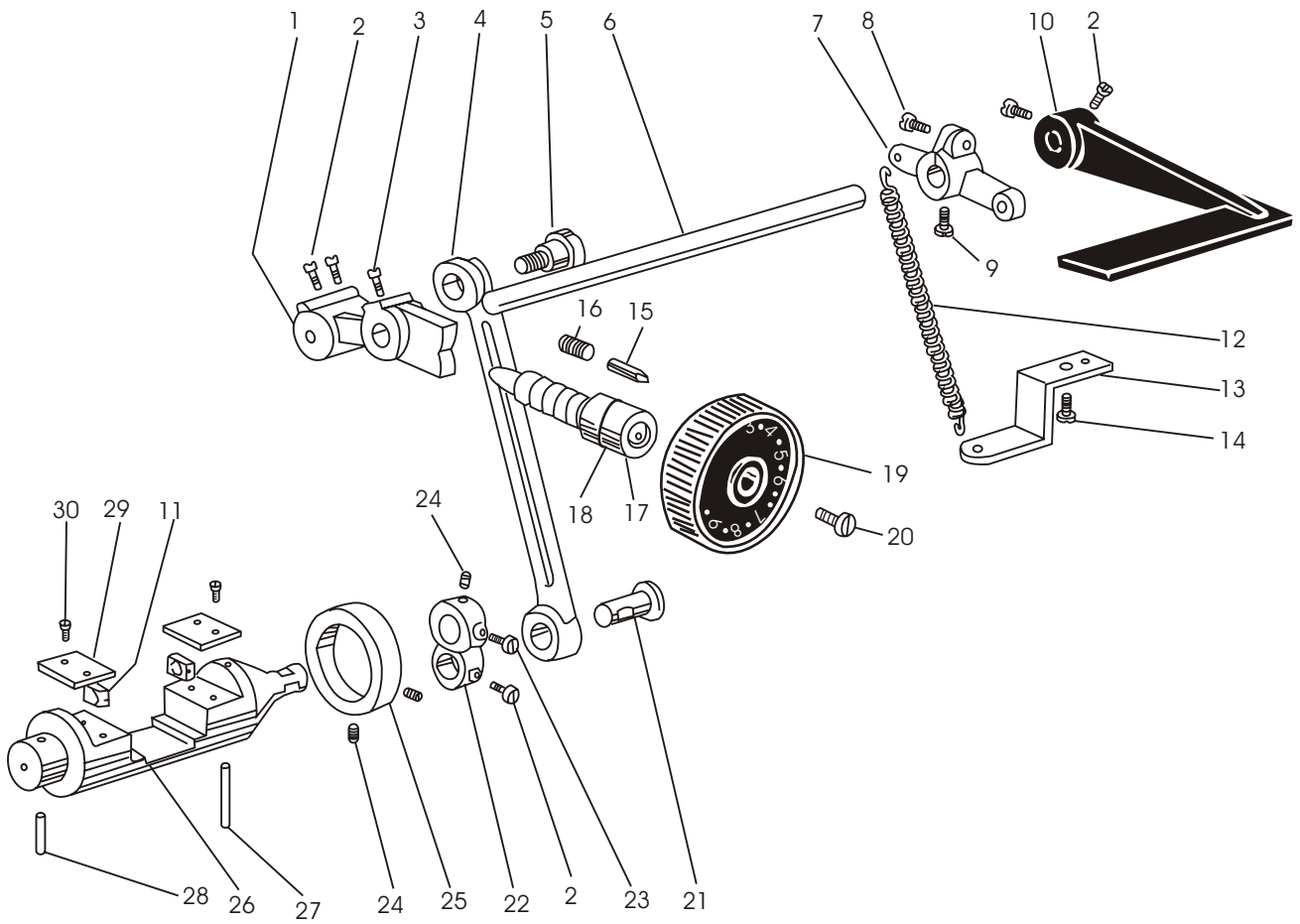

8. Stitch Length Adjusting Parts

Item	Part number	Description	Pcs
1.	1WF4-025	Stitch length adjusting swing lever	1
2.	1WF4-030	Screw	5
3.	1WF4-026	Set screw	1
4.	1WF4-014	Stitch length link	1
5.	1WF4-028	Stitch length link eccentric shaft	1
6.	1WF4-046	Reverse sewing shaft	1
7.	1WF4-047	Reverse sewing crank	1
8.	1WF4-027	Tension screw	1
9.	1WF4-021	Set screw	1
10.	1WF4-048	Reverse sewing lever	1
11.	1WF4-040	Sliding block	2
12.	1WF4-049	Spring	1
13.	1WF4-050	Spring holder	1
14.	1FW4-051	Screw	1
15.	1WF4-024	Stop pin	1
16.	1WF5-006C3	Pin spring	1
17.	1WF4-023	Stitch length adjusting bolt	1
18.		O-gasket	1
19.	1WF4-022	Stitch length dial	1
20.	1WF5-009	Screw	1
21.	1WF4-013	Stitch length adjusting crank shaft	1
22.	1WF4-015	Stitch length adjusting crank	1
23.	1WF2-038	Tension screw	1
24.	1WF4-016	Set screw	3
25.	1WF4-053	Collar	1
26.	1WF4-057	Reverse sewing adjusting stand	1
27.	1WF4-045	Oil wick	1
28.	1WF4-039	Oil wick	1
29.	1WF4-056	Sliding block guide	2
30.	1WF1-011	Tension screw	4

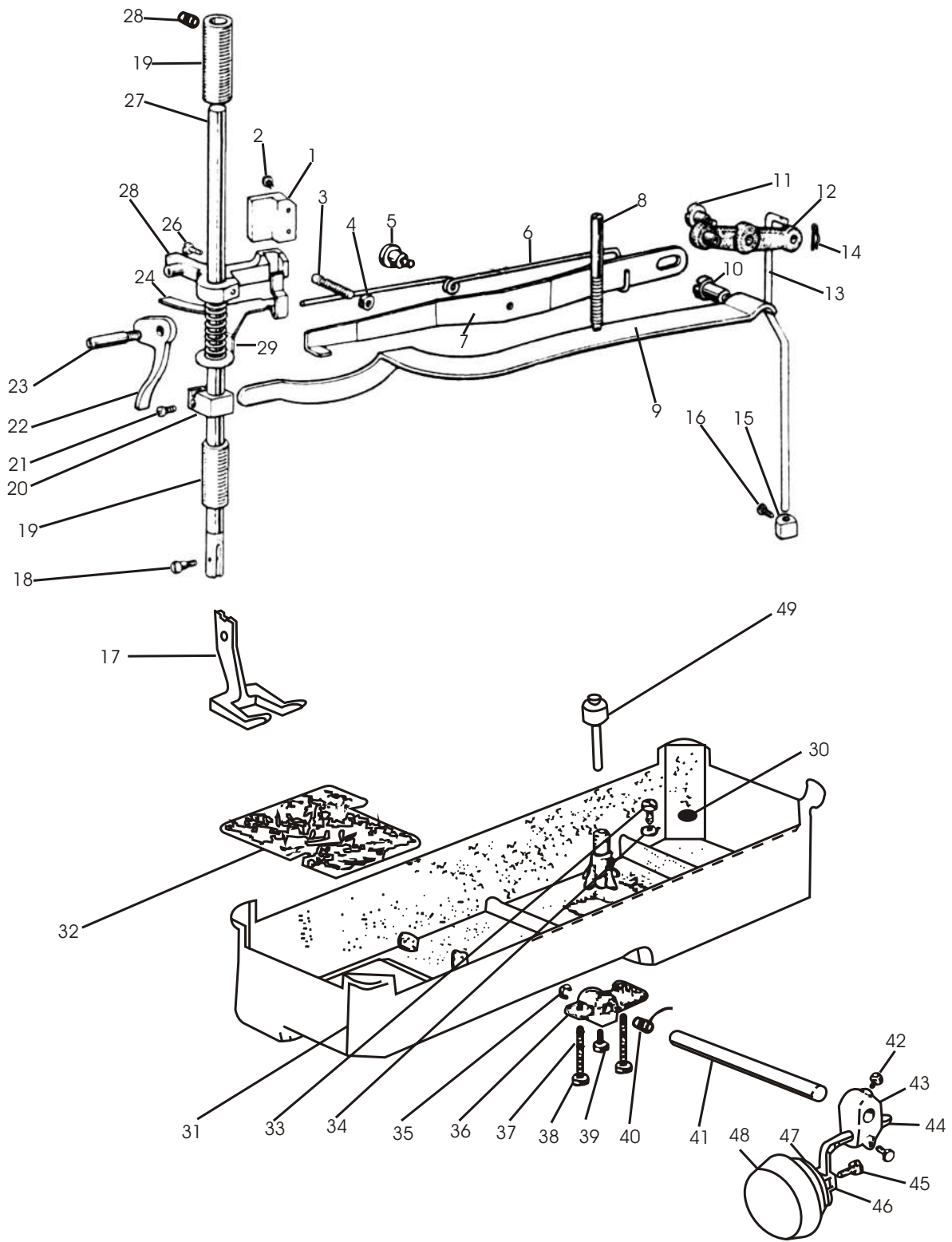

9.Presser Foot Lift Parts

Item	Part number	Description	Pcs
1.	1WF5-040	Sliding block rail	1
2.	1WF5-039	Screw	2
3.	1WF3-011	Screw	1
4.	1WF3-010	Nut	1
5.	1WF3-013	Screw	1
6.	1WF3-014	Spring	1
7.	1WF3-012	Knee lift lever	1
8.	1WF3-015	Pressure adjusting screw	1
9.	1WF3-016	Pressure bar spring lever	1
10.	1WF3-018	Screw	1
11.	1WF3-017	Screw	1
12.	1WF3-019	Knee control crank assembly	1
13.	1WF3-021	Knee lift prop rod	1
14.	1WF3-020	Split pin	1
15.	1WF3-024	Stop collar	1
16.	1WF3-025	Screw	1
17.	1WF3-001(9WF3-001)	Presser foot	1
18.	1WF3-002	Set screw	1
19.	1WF3-004	Bushing for presser bar shaft	2
20.	1WF3-005	Springy lever holder	1
21.	1WF2-006	Screw	1
22.	1WF3-023	Presser foot lift lever	1
23.	1WF3-022	Screw	1
24.	1WF3-007	Thread releasing lever	1
25.	1WF3-008	Presser bar guide	1
26.	1WF3-009	Tension screw	1
27.	1WF3-003	Presser bar	1
28.	1WF3-023	Screw	2
29.	1WF3-006	Spring	1
30.	22F9-012	Magnet	1
31.	58F0-001A1	Oil reservoir	1
32.	58F0-001	Oil gasket	1

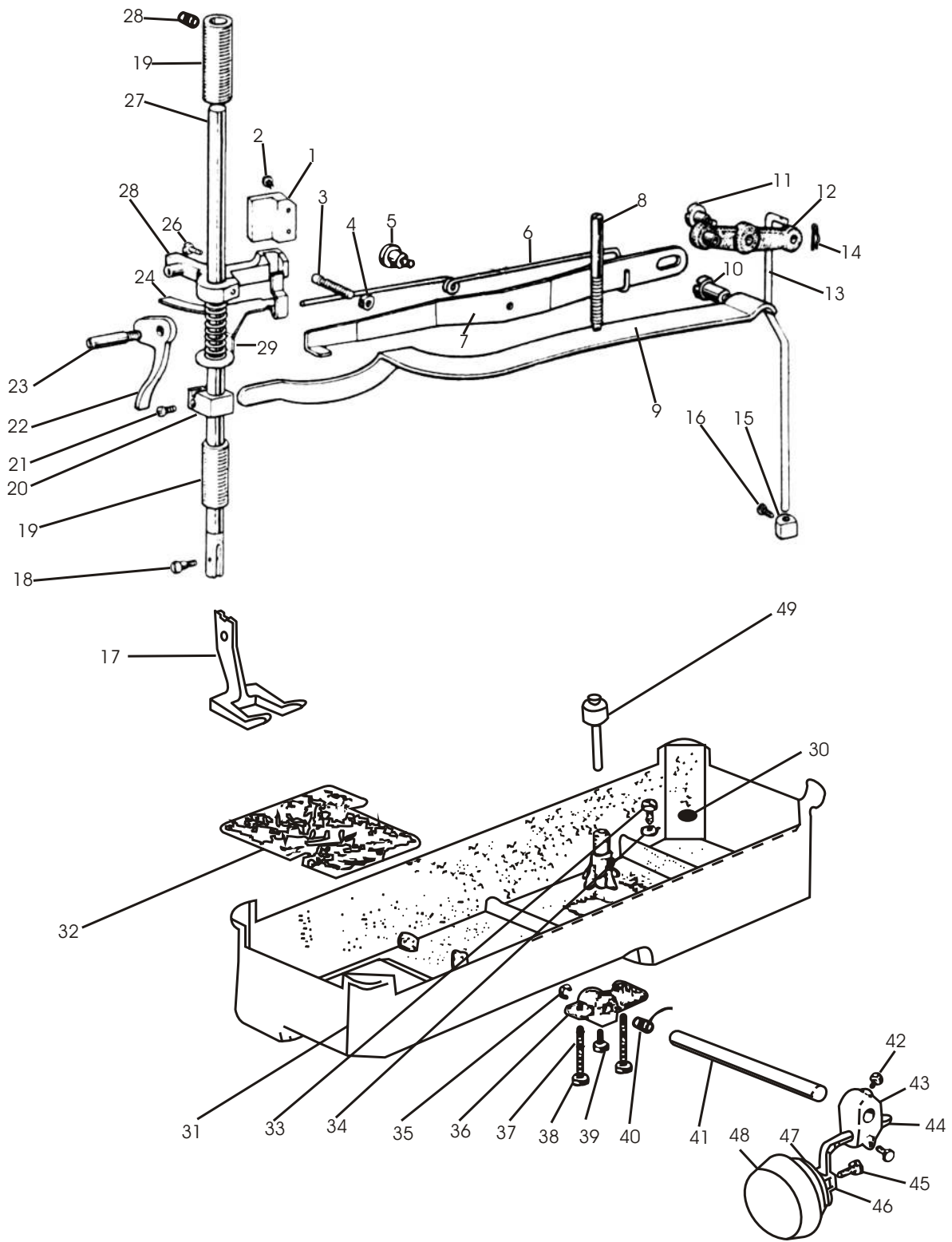

9.Presser Foot Lift Parts

Item	Part number	Description	Pcs
33.	22T9-001A2	Screw	1
34.	22T9-001A3	Washer	1
35.		Retain ring	1
36.	1WF3-028	Knee lifter stop bracket	1
37.	22T9-001A9	Adjust screw	2
38.	22T9-001A10	Adjust nut	2
39.	22T9-007C2	Screw	1
40.	22T9-001A7	Position spring	1
41.	1WF3-027	Hinge pin	1
42.	22T9-003B4	Screw	2
43.	22T9-003B3	Connector	1
44.	22T9-003B2	Bent rod	1
45.	22T9-003B7	Screw	1
46.	22T9-003B6	Knee lifter bell bracket	1
47.	22T9-003B5	Bell	1
48.	22T9-003B8	Pat	1
49.	1WF3-026	Knee lifter prop ear	1

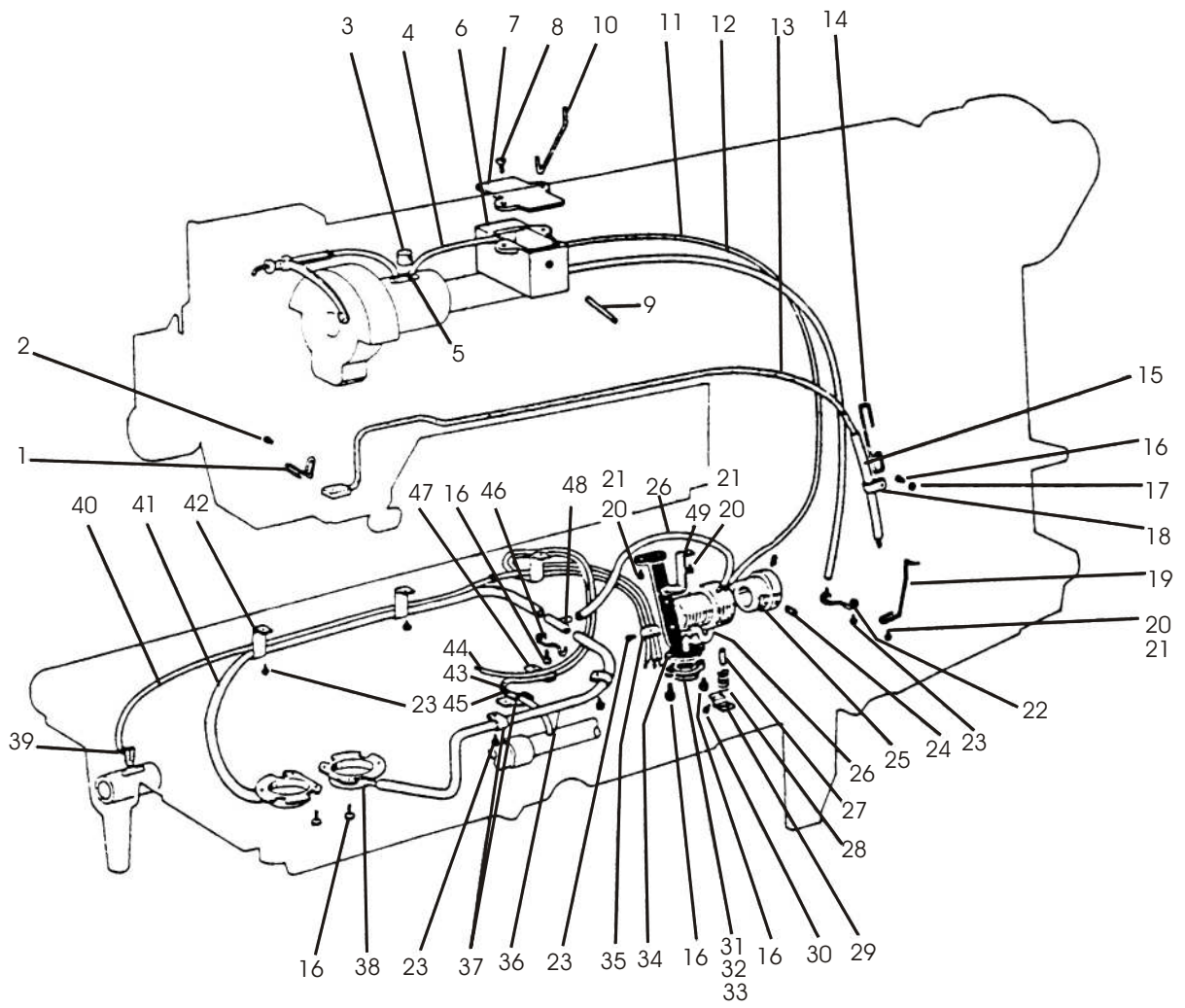

10.GC20606 Lubrication Parts

Item	Part number	Description	Pcs
1.	1WF6-001	Oil felt press spring	1
2.	1WF6-034	Screw	1
3.	1WF6-003	Oil felt	1
4.	1WF6-005A	Oil pipe	1
5.	1WF6-004	Oil wick	1
6.	1WF6-007	Oil cup	1
7.	1WF6-008	Oil cup cover	1
8.		Screw	2
9.	1WF6-009	Spring pin	1
10.	1WF6-006	Wick press spring	1
11.	1WF6-010	Oil pipe	1
12.	1WF6-011	Oil drain pipe	1
13.	1WF6-002	Oil wick	1
14.	1WF6-013	Oil pipe position finger	1
15.	1WF6-012	Needle bar oil return pipe	1
16.	1WF1-024	Screw	10
17.		Washer	1
18.	1WF6-042	Oil pepe clamp	1
19.	1WF6-014	Oil pipe set spring	1
20.	1WF1-011	Screw	4
21.	22T1-007	Washer	4
22.	1WF6-021	Oil pipe end clamp	1
23.	1WF1-026	Screw	8
24.	1WF2-053	Screw	2
25.	1WF2-054	Bushing	1
26.	1WF6-027	Oil pipe	2
27.	1WF6-025	Plunger	1
28.	1WF6-024	Spring	1
29.	1WF6-023	Braket for spring	1
30.	1WF6-026	Screw	1
31.	1WF6-018	Oil filter	1

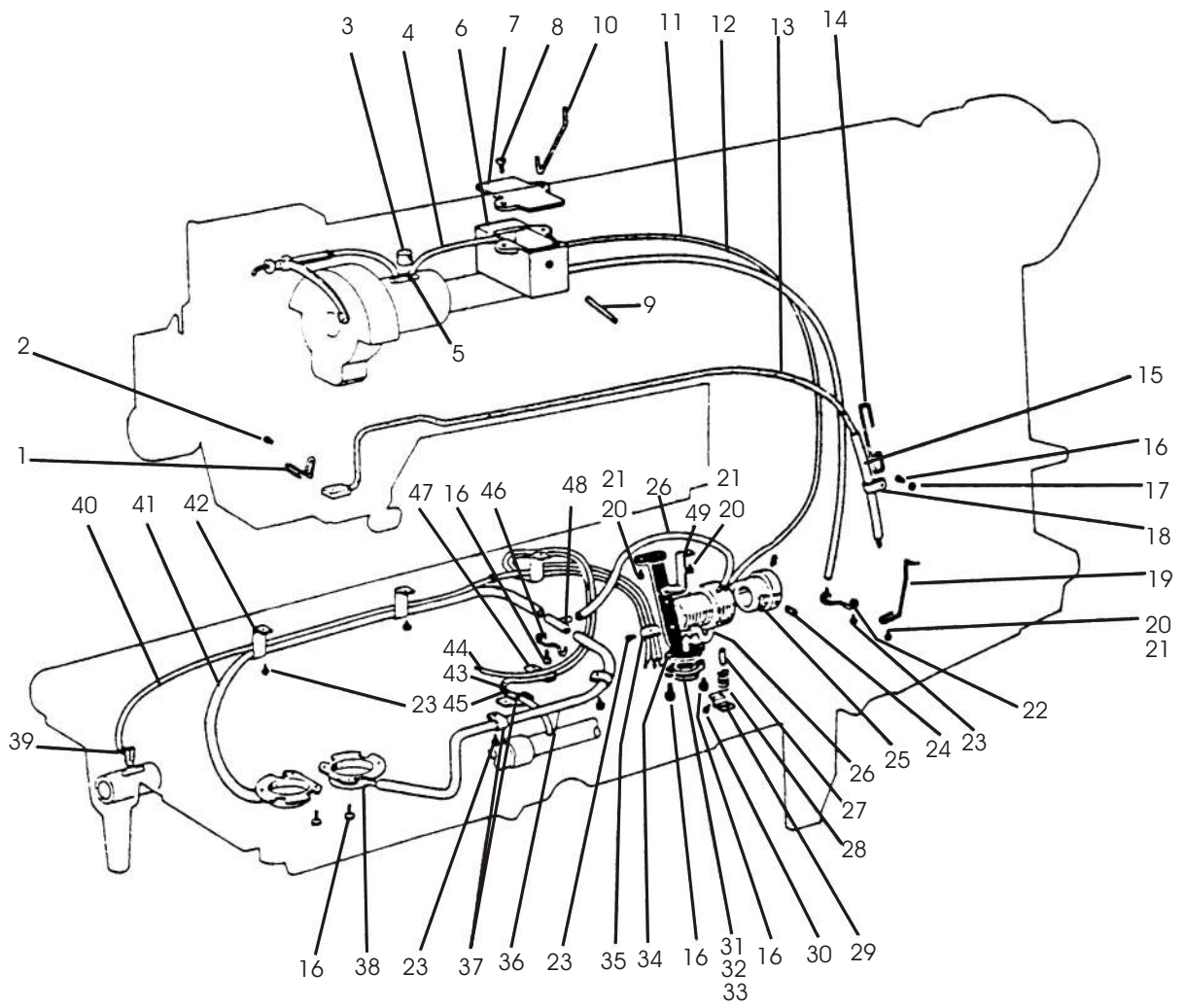

10.GC20606 Lubrication Parts

Item	Part number	Description	Pcs
32.	1WF6-019	Washer	1
33.	1WF6-020	Filter screw	1
34.	1WF6-017	Oil filter bracket	1
35.	1WF6-028	Oil pipe clamp	1
36.	1WF6-035	Oil pipe	1
37.	1WF6-036	Oil pipe clamp	3
38.	1WF6-038	Oil tray assembly	2
39.	1WF6-041	Oil wick	1
40.	1WF6-040	Oil pipe	1
41.	1WF6-039	Oil pipe	1
42.	1WF6-034	Pipe clamp	3
43.	1WF6-032	Oil pipe	2
44.	1WF6-037	Oil wick	1
45.	1WF6-033	Oil wick	1
46.	1WF6-030	3-nozzle oil mouth bracket	1
47.	1WF6-031	Oil pipe clamp	1
48.	1WF6-029	3-nozzle oil mouth bracket	1
49.	1WF6-015	Oil filter bracket	1

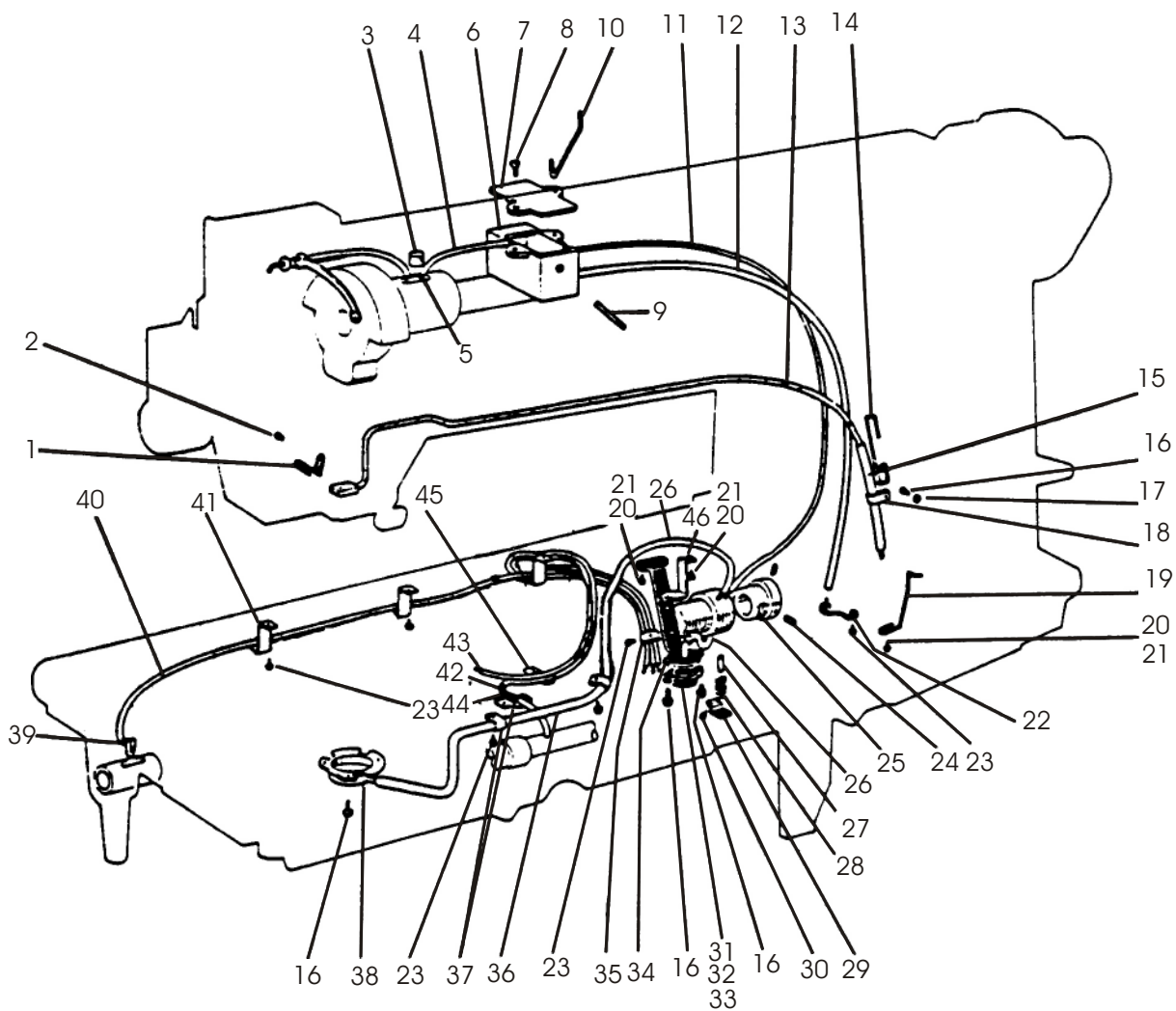

11.GC20606-1 Lubrication Parts

Item	Part number	Description	Pcs
1.	1WF6-001	Oil felt press spring	1
2.	1WF6-034	Screw	1
3.	1WF6-003	Oil felt	1
4.	1WF6-005A	Oil pipe	1
5.	1WF6-004	Oil wick	1
6.	1WF6-007	Oil cup	1
7.	1WF6-008	Oil cup cover	1
8.		Screw	2
9.	1WF6-009	Spring pin	1
10.	1WF6-006	Wick press spring	1
11.	1WF6-010	Oil pipe	1
12.	1WF6-011	Oil drain pipe	1
13.	1WF6-002	Oil wick	1
14.	1WF6-013	Oil pipe position finger	1
15.	1WF6-012	Needle bar oil return pipe	1
16.	1WF1-024	Screw	10
17.		Washer	1
18.	1WF6-042	Oil pipe clamp	1
19.	1WF6-014	Oil pipe set spring	1
20.	1WF1-011	Screw	4
21.	22T1-007	Washer	4
22.	1WF6-021	Oil pipe end clamp	1
23.	1WF1-026	Screw	8
24.	1WF2-053	Screw	2
25.	1WF2-054	Bushing	1
26.	1WF6-027	Oil pipe	2
27.	1WF6-025	Plunger	1
28.	1WF6-024	Spring	1
29.	1WF6-023	Bracket for spring	1
30.	1WF6-026	Screw	1
31.	1WF6-018	Oil filter	1

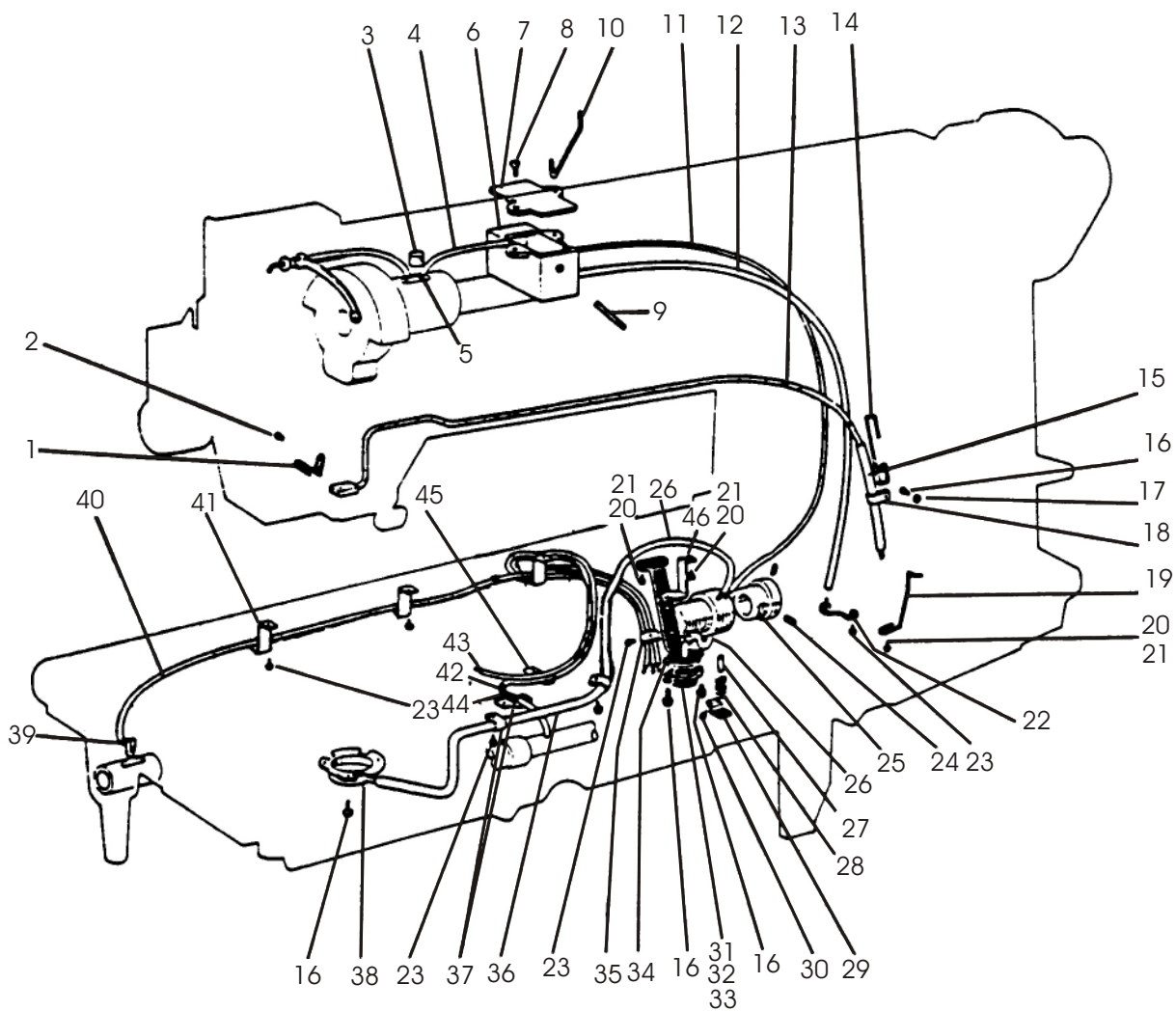

11.GC20606-1 Lubrication Parts

Item	Part number	Description	Pcs
32.	1WF6-019	Washer	1
33.	1WF6-020	Filter screen	1
34.	1WF6-017	Oil filter bracket	1
35.	1WF6-028	Oil pipe clamp	1
36.	1WF6-035	Oil pipe	3
37.	1WF6-036	Pipe clamp	2
38.	1WF6-038	Oil tray assembly	1
39.	1WF6-041	Oil wick	1
40.	1WF6-040	Oil pipe	1
41.	1WF6-034	Pipe clamp	3
42.	1WF6-032	Oil pipe	2
43.	1WF6-037	Oil wick	1
44.	1WF6-033	Oil wick	1
45.	1WF6-031	Oil pipe clamp	1
46.	1WF6-015	Oil filter bracket	1

12

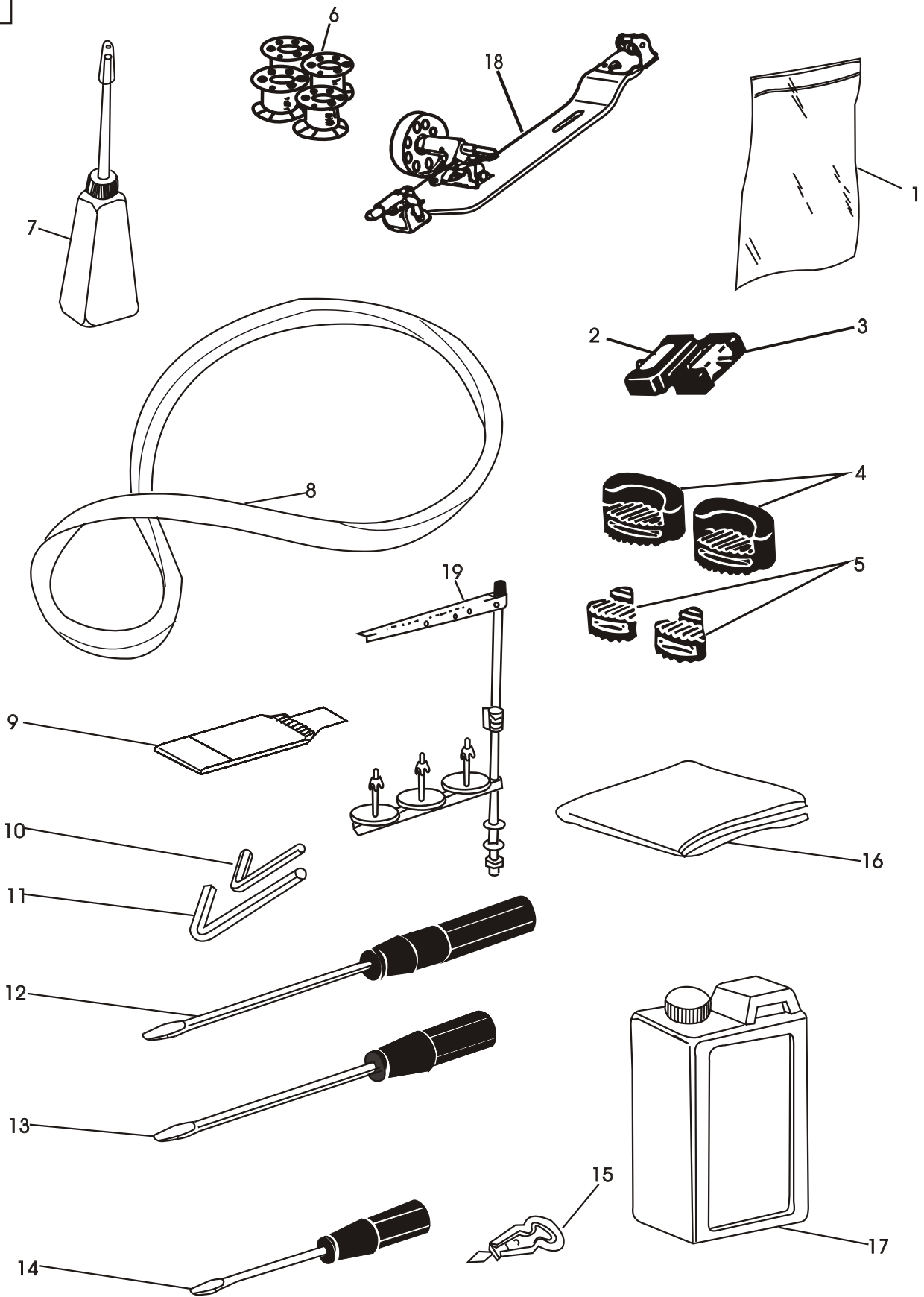

12.Accessories

Item	Part number	Description	Pcs
1.	33TF-010	Accessories bag	1
2.	22T9-007F1	Hinge pin	2
3.	22T9-007F2	Hinge pin socket	2
4.	22T9-009	Cushion	2
5.	22T9-010	Cushion	2
6.	1WF2-065	Bobbin	4
7.	33TF-011	Oil pot	1
8.	33TF-016	V-belt	1
9.	1F-009	Needle	1
10.	1F-011	Hex key	1
11.	1F-010	Hex key	1
12.	33TF-012	Screwdriver	1
13.	33TF-013	Screwdriver	1
14.	33TF-014	Screwdriver	1
15.	58T0-007C	Thread tweezer assembly	1
16.	22T9-018	Arm cover	1
17.	1F-012	Oil tank	1
18.	S14420020	Bobbin winder	1
19.	1F-014(33TF-019)	Thread stand	1